

Zeitschrift



VW Cross Coupe GTE concept.

February 2015

IN THIS 30th ANNIVERSARY ISSUE:

Club Veedub turns 30!
The Toy Department
Duke's Day at Freshwater
A history of ignitions

VWs coming in 2015
Joe's Parkes adventures
Watercooled Summer Run
Plus lots more...



The Legend Never Dies

Club VeeDub Sydney.

www.clubvw.org.au

A member of the NSW Council of Motor Clubs. Also affiliated with CAMS.



Club VeeDub Sydney Committee 2014-15.

President:	Steve Carter president@clubvw.org.au	0490 020 338
Vice President:	Craig Adams vicepresident@clubvw.org.au	0404 184 893
Secretary and: Membership:	Norm Elias secretary@clubvw.org.au	0421 303 544
Assist. Secretary:	David Birchall assistantsecretary@clubvw.org.au	(02) 9534 4825
Treasurer:	Martin Fox treasurer@clubvw.org.au	0411 331 121
Editor:	Phil Matthews editor@clubvw.org.au	0412 786 339
Assistant Editor:	Lily Matthews	
Webmaster:	Aaron Hawker webmaster@clubvw.org.au	0413 003 998
Book and DVD Librarian:	Joe Buttigieg library@clubvw.org.au	0449 291 642
Tool Librarian:	Bob Hickman tools@clubvw.org.au	(02) 4655 5566
Merchandising:	Raymond Rosch sales@clubvw.org.au	(02) 9601 5657
Assistant Merch:	Kira and Bettina Rosch	
Raffle Officer:	Christine Eaton	(02) 9520 4914
Vintage Registr:	John Ladomatos vintage@clubvw.org.au	0449 236 076
VW Nationals Committee:	David Birchall Aaron Hawker Mark Stevens, Bob Hickman, Craig Adams	(02) 9534 4825 0413 003 998
Motorsport Captain:	Rudi Frank motorsport@clubvw.org.au	0418 442 953
VW Motorsport Committee:	John Ladomatos Andrew Corless	Craig & Martha Adams Norm Robertson (JP) Brian Walker
General Committee:	Martha Adams Leigh Harris Jeff Swords Eddie Fleita	Shirley Pleydon Ken Davis Sue Monaghan Atakhan Yilmaz
Chair:	Bruce Walker	wwevents@dodo.com.au
Vice-Chair:	Rhiannon Walker	rhiannon_w@live.com.au
Secretary:	Mandy Conway	mandycnwy@gmail.com
Treasurer:	Rhiannon Walker	rhiannon_w@live.com.au
Registrar:	Iven Laufer	(02) 6254 1142
Merchandise:	Jay Pozzi	jay_1965vw@hotmail.com

Canberra Committee.

Club VeeDub membership.

Membership of Club VeeDub Sydney is open to all Volkswagen owners. The cost is \$45 for 12 months.

Monthly meetings.

Monthly Club VeeDub meetings are held at the Greyhound Social Club Ltd., 140 Rookwood Rd, Yagoona, on the **third Thursday of each month**, from 7:30 pm. All our members, friends and visitors are most welcome.

Correspondence.

Club VeeDub Sydney
PO Box 1340
Camden NSW 2570

Our magazine.

Zeitschrift (German for 'magazine') is published monthly by Club VeeDub Sydney Inc. Members with email details receive Zeitschrift as a full-colour PDF from our website.

We welcome all letters and contributions of general VW interest. These may be edited for reasons of space, clarity, spelling or grammar. Deadline for all contributions is the first Thursday of each month; late submissions will be held over.

Opinions expressed in Zeitschrift are those of the writers, and do not necessarily represent those of Club VeeDub Sydney. Club VeeDub Sydney, and its members and contributors, cannot be held liable for any consequences arising from any information printed in the magazine.

Back issues (2007-on) are available as full-colour PDFs from the Webmaster at the monthly meeting - please bring your own USB stick. These are also available at www.clubvw.org.au

Articles may be reproduced with an acknowledgment to *Zeitschrift, Club VeeDub Sydney.*

We thank our VW Nationals sponsors:

27 years.

Volkswagen Group Australia	Klaack Motors
Andrew Dodd Automotive	Stan Pobjoy Racing Engineering
C & S Automotive	Vintage Vee Dub Supplies
H&M Ferman	Volksbahn Autos Pty Ltd

20 years and over.

Aust VW Performance Ctr	Shannons Car Insurance
Mick Motors	Wolfsburg Motors Sydney
North Rocky & Import Parts	

15 years and over.

Harding Performance	Reliable Automotive Services
Indian Automotive	Unicap Pty Ltd
Mobile Model Cars	Wayne Penrose VW Engineering

10 years and over.

All Metal Bumpers	Custom Vee Dub
BWA Auto	Defender Safety
Black Needle Auto Upholstry	Euro Automotive
Canberra VW Centre	NRMA Insurance
Classic Vee Dub	Wolfsburg Auto Melbourne
Cupid Wedding Cars	Wurth Fasteners Australia

5 years and over.

Antique Tyres	Red Van Tyre Colouring
Artemi's T-Shirts	Rod Penrose Racing
Camden GTI Performance	Volkscare Melbourne
Custom T-Shirts	Volkshome Automotive
Expert Signs	Volksmuller
Gold Coast Vee Dub	VW Classic Kirrawee
Nulon Australia	VW Magazine Australia
Quik Strip Bankstown	Westside Mufflers

*Please have respect for the committee members and their families
by only phoning at reasonable hours.*

THIRLMERE FESTIVAL OF STEAM

Sunday 1st March 2015

The 2015 Thirlmere Festival of Steam is a great escape into our railway past - it's Australia's biggest rail heritage festival, featuring the largest number of steam locomotives to be found anywhere - five steam locomotives in operation!

The Festival is a fantastic day out for all the family, with all the fun of a country fair. Thirlmere village comes alive with a street parade, vintage steam machinery and historic vehicles, food, music, country crafts and displays. Over a hundred market stalls will offer their produce, craftwork, toys, snacks and specialty foods for sale.

The Festival is centred on historic Thirlmere Railway Station and Australia's largest display of historic locomotives, carriages and rail memorabilia at the Rail Heritage Centre, Thirlmere. A popular feature of the Festival is the huge variety of operational steam locomotives, all in operation on the day to provide frequent vintage steam train trips on the Thirlmere Heritage Railway to Buxton and back.

The ever-popular gala parade features bands, floats, performers and displays from local groups, car clubs and businesses, while classic and historic vehicles (including VWs) will line the streets. The parade starts at 1.00 pm. The Steam Festival also has lots of attractions especially for children, including miniature train rides, model train layouts and amusement rides of all kinds.

Entertainment through the day will include 'Music in the Park' from 9.30 am. The music program includes jazz, folk, and country music, and features bands and singers from Picton High School, as well as other popular and acclaimed local acts.



It is with great pride that we extend an official invitation to Club VeeDub Sydney to join us at the Thirlmere Festival of Steam 2015 at Thirlmere, NSW, on **Sunday 1st March 2015**.

All of the car clubs will be located together on both sides of Westbourne Avenue. Please enter from the northern end of Westbourne Avenue, as entry from all other locations will be prohibited. Please ensure that all members are in position by **no later than 9:30am**. There will be overflow parking for latecomers, but it will not be near the show cars. The earlier you arrive the better chance of a good spot. **Join the Club VeeDub convoy from Uncle Leo's Caltex Servo, Liverpool Crossroads, at 7:15am for a 7:30am departure.**

The festival hours will be from 10:30am through to 5:00pm. Apart from the parade, which starts at 1:00pm sharp (marshalling from 12:30pm), vehicle movements will be kept to a minimum.

While there is no limit on the number of club display cars, we will be restricting parade vehicle numbers to **2 per club** to allow the parade to move freely and to reduce traffic snarls. If your club could select their appropriate vehicles to enter the parade and let the parade manager know on the day, that would be appreciated. The owners would then be required to ensure their vehicles are made available at the marshalling point in Westbourne Ave at the appropriate time (12:30pm). If they are not there on time, they will not be participating in the parade.

Please don't hesitate to contact me by phone (02) 4677 2462, mobile phone 0409 952 874 or email krmmodels@gmail.com



Keiran Ryan, Events Manager

www.thirlmerfestivalofsteam.com.au

4th annual German Autofest

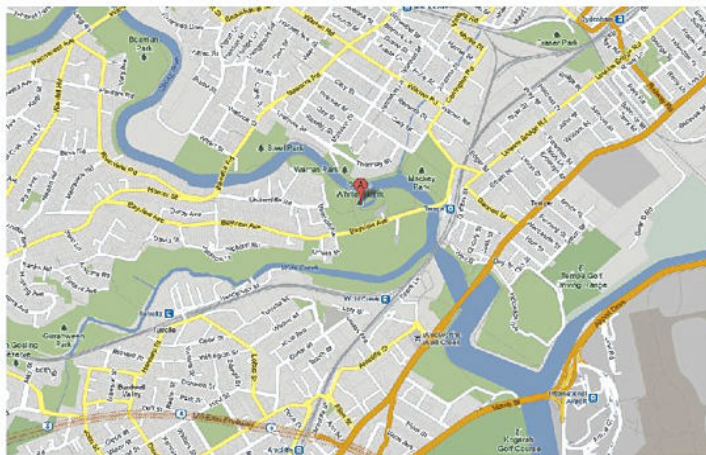

Sunday 1st March 2015
Gough Whitlam Park
Bayview Ave, Earlowood
9:00 AM - 3:00 PM

All German vehicles welcome – Volkswagen, Audi, BMW, Porsche, Mercedes etc. Original classics and late model.

\$10 to show your car. Bring your own picnic lunch.
Organised by the Mercedes Benz Club of NSW.

Contact John Assarapin on 0418 785 815 for more information.



club



30TH

ANNIVERSARY

CRUISE!

SUNDAY 8TH MARCH

- ❖ Meet at Hungry Jack's at North Parramatta (opposite Bunnings) at 9am.
- ❖ Depart about 9:30am after having a relaxing brekkie and coffees.
- ❖ Follow the Navigation instructions and answer the trivia questions along the way! (hint: bring a friend to help!)
- ❖ Finish at Settlers Arms Inn at St. Albans for lunch and drinks. All tarmac roads; no dirt or gravel! :) *Run by Phil and Lily! :)*

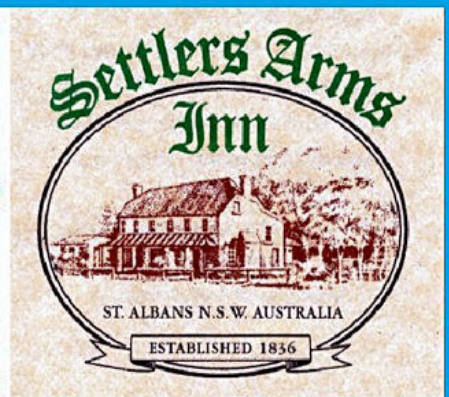
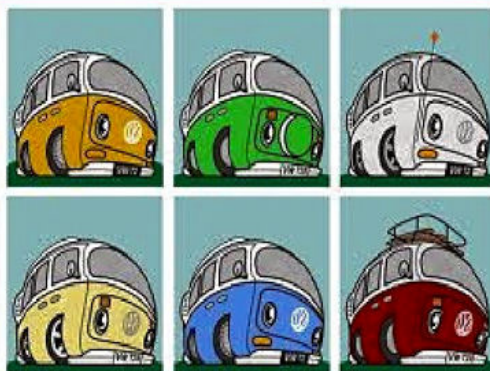

Suspension Tech Night at Heasman Steering & Suspension 11th March at 7.30pm

HEASMAN
STEERING & SUSPENSION

PH 02 9557 3739

[HOME](#)

[ABOUT](#)

[SERVICES](#)

[PRODUCTS](#)

[BLOG](#)

[CONTACT](#)



Club Vee Dub have been invited by the Mercedes Benz club to attend a tech night at Heasmans with them.

Topics covered will be Wheel Alignment, Suspension Design & Theory and Corner Weighting

455-463 Princes Highway
(cnr Railway Road)
Sydenham NSW 2044

IMPORTANT

Spaces are limited, you must call Steve Carter on 0490 020 338 before 6th March to register your interest

Old Car Social Club

11th Annual Show & Shine Sunday 22nd March 2015 at Flower Power, Moorebank

In conjunction with
The Lions Club of the City of Liverpool,
in aid of diabetic awareness

- Gates open 7:30am
- Cars in position by 9:00am
- Trophies will be presented at 1:30pm

We invite you to show off your classic Volkswagen!



Supported by



Entry Fee: Display Cars \$10.00 (includes driver and passenger)
Spectators \$2, Family \$5

Entry forms available at www.oldercarsocialclub.com.au

For further enquiries contact: 0405 385 235

Volkswagens meet at McDonalds Revesby — cnr River Rd & Milperra Rd — at 7:30am.

VW Nationals 2015 3 months and it'll be here.

23rd & 24th May 2015 - Sydney, Australia.

Contact David (02) 9534 4825

Or visit clubvw.org.au



The Legend Never Dies

Von dem Herrn Präsident.

Hi all,

Well, we've had a great event to kick start the year, the VW Summer Cruise on Sunday 1st February. The cruise was very well attended, with good weather. See the report with photos in this issue. Thanks to Matt White, Norm Robertson and Rudi Frank for taking up the reins after Aaron's move to Melbourne, and to everyone who attended.

There was a sour note to the cruise. I had a phone call from a disgruntled member of the public complaining about some people on cruise driving dangerously. I didn't witness it happening but on further investigation I learnt that the car the complainant was in failed to keep left in an overtaking lane. Still no excuse for dangerous driving. A lot of people from outside club attended, so it may have been non club members behaving badly.

As I write this report the annual Pizza and Pasta night is on tonight at Monte Carlo's at Riverwood, should be good night.

Later this month the Sydney VW Drag Racing at WSID was to be held. Unfortunately the track is under new management and they refused to honour the pricing and arrangements that Craig Hughes from VWMA had with the previous management. Craig was forced to cancel the event. This is a sad blow to the Sydney VW scene. This event was bringing VW enthusiasts from all over the country which in turn would add to the economy of NSW and the country.

In March we have the car display at Thirlmere Festival of Steam on the 1st and on the same day is the German Autofest at Earlwood, two great events clashing which is a shame.

There are so many interesting events coming up soon, too many to describe here, so keep an eye on the club calendar in the magazine or on the club website.

The VW Nationals will be here again before we know it. Planning is well under way. We will need some help setting up, packing up and during the day. If you can lend a hand at either the Supersprint in Western Sydney or on show day it would be much appreciated.

See you soon,

Steve Carter



2015 Supersprint.

Good News for Good Sports! Our annual Supersprint this year is to be held at Eastern Creek, at Sydney Motor Park. I know this will make you all happy as it saves that BIG DRIVE south and you always wanted to help run this event. So here is your chance!

We need to have enough CLUB members to give a hand, so the usual faces are not the usual faces doing the hard yards.

Talk to mum, talk to the wife, call the girl or boyfriend

are ask are you allowed to help. Better still bring them along then we only need half as many.

Talk to Craig, Norm or Rudi in fact talk to anyone on the Committee about giving a hand. See Club Vee Dub directory for contact numbers.

Thanks

Norm Robertson

Kanberra Kapitel report.

Hi everyone, anyone would think winter was knocking at the door with these temperatures we have been having. January was a quiet month for the club as everyone returned to work and school schedules. I hope you all had a relaxing break.

On Saturday 14 Feb we are having a cruise to Gundaroo for lunch, and then the chapter AGM. It's a great chance to get your car out for a drive and have some lunch with others. I need to book seats for this one, so please let me know quickly at vwevents@dodo.com.au We've emailed out about this one so you should be thinking about it now. I'll contact those coming with the timings and such. Gundaroo is a great town to visit, come along!

On Sunday 8 March, the Wheels Car Show will once again take place at Kings Park, situated between Russell and the Carillon. A great opportunity for those with historic registration to bring their cars along and show them off. More details about timings will be forthcoming, so watch your email.

On Sunday 29 March VW owners are invited to join the Volkswagen Drive for the Community in support of the Canberra Hospital Foundation, promoted by Lennox Volkswagen, Phillip. All proceeds go to the Canberra Hospital. Participants will go on a drive past some of Canberra's icons before returning to Thoroughbred Park for a family friendly event. VIP registration is \$100, which guarantees a place in the first 150 cars with a police escort. Convoy Registration is \$50. All entries receive a raffle ticket for a chance to win the last VW Up! in Australia. More details have just been loaded to the site and registrations can now be applied for at <http://canberrahospitalfoundation.org.au> Just follow the links for the VW day and you will find the info there. Also see the flyer (over the page - Ed).

Saturday 18 April will see a leisurely drive to Googong Dam for a family picnic, more to come.

Weekend of 23 - 24 May are the Club VeeDub Nationals. Intention is to have a cruise up this year, leaving Saturday early afternoon and staying overnight close by the Fairfield Showground, Penrith. More to come, if you want to see a great VW show be ready to head to Sydney and support our club. Great cars on display, stalls (new and secondhand), merchandise, food, its all there.

Catch you all soon.

Bruce



Klub Kalender.

**** All information correct at time of printing but subject to change - events are sometimes altered or cancelled without notice. Check www.clubvw.org.au for the latest information and any changes.*

February.

Thursday 19th:- CLUB VW MONTHLY MEETING at the **Greyhound Social Club**, 140 Rookwood Rd. Yagoona (right next to Potts Park). Get the latest VW news and views, plus VW socialising, drinks, raffles, trivia and plenty of prizes. Lots of fun, all welcome. 8:00pm start.

Saturday 21st:- Sydney Showdown VW Drag Racing at WSID, Eastern Creek.. ****EVENT CANCELLED***

Monday 23rd:- Canberra General Meeting at the Canberra Labor Club, 16 Petrie Plaza, Civic, at 7:30pm.

March.

Sunday 1st:- Thirlmere Festival of Steam 2015 at Thirlmere, NSW. Steam train rides, Trainworks railway museum, model railways, bands, dancers, food and drink stalls, market traders, kids rides, classic car display and parade. **Club VW Convoy meets at Uncle Leo's Caltex at Liverpool Crossroads (UBD 288 D6) at 7:30am for a 7:45am departure.** Arrive by 9:30am. Street parade (max 2 VWs) at 1pm.

Sunday 1st:- Sydney German Autofest at Gough Whitlam Park, Bayview Ave Earlwood. Organised by the Mercedes-Benz Club of NSW. All German marques are invited to display on this classic picnic day. A celebration of the German automotive industry, both traditional and modern. Displays from Merc-Benz, Porsche, BMW, Audi, Volkswagen and micro cars. All cars in place by 9am, \$10 to display a car. Contact John Assarapin (MBC) on 0418 785815 aft 5pm.

Thursday 5th:- Magazine Cut-off Date for articles, letters and For-Sales.

Sunday 8th:- Club Veedub 30th Anniversay Cruise. Celebrate our Club's 30th birthday by coming on a tribute navigation run! Meet at Hungry Jack's at North Parramatta, off Church St opposite Bunnings, at 9:00am. Bring a friend to navigate. Depart at 9:30am after coffees. Follow the instructions, spot the landmarks, answer the questions. Cruise to St Albans (where we went in 1985) for a beer and country pub lunch. All tarmac, no gravel roads! Trophies for the winners. Organised by Phil and Lily.

Wednesday 11th:- Suspension Tech Night at Heasman Steering and Suspension, 455 Princes Hwy Sydenham. Organised by the Mercedes Club. Limited spaces; call Steve Carter on 0490 020 338 to book your spot.

Thursday 12th:- Committee Meeting at the Greyhound Social Club, 140 Rookwood Rd. Yagoona (next to Potts Park).

SUNDAY 29 MARCH

2015

VOLKSWAGEN DRIVE FOR THE COMMUNITY



**SAVE THE
DATE!**

Join Australia's Volkswagen enthusiasts in the 2015 drive through the nation's capital.

Volkswagen owners, past and present, are invited to join the historical procession of Volkswagens, past national icons such as Parliament House, the National War Memorial and the National Gallery, then return to Thoroughbred Park for a mass gathering of Volkswagen enthusiasts from around Australia.

Proceeds will support the Canberra Hospital Foundation. Back by popular demand, make sure you save the date.

Proudly Supporting



CANBERRA HOSPITAL
Foundation
Heart of the community

Supported by Canberra's
Volkswagen dealers
Lennox Volkswagen and
Gerald Slaven Volkswagen



www.canberrahospitalfoundation.org.au

Thursday 19th:- CLUB VW MONTHLY MEETING at the **Greyhound Social Club**, 140 Rookwood Rd. Yagoona (right next to Potts Park). Get the latest VW news and views, plus VW socialising, drinks, raffles, trivia and plenty of prizes. Lots of fun, all welcome. 8:00pm start.

Sunday 22nd:- Old Car Social Club Show n Shine at Flower Power, Moorebank. We invite you to bring your classic VW to display. Gates open at 8:00am, Trophy presentation 2pm. Display cars \$10 (includes driver and passenger), spectators \$2, family \$5. Food and drinks available. Contact Neil 0418 943518 or Ray 0411251 120. VWs meet first at McDonalds,

Revesby, cnr River and Milperra Rds, at 7:30am. Then we can arrive, and park, together.

Monday 30th:- Canberra General Meeting at the Canberra Labor Club, 16 Petrie Plaza, Civic, at 7:30pm.

April.

Thursday 2nd:- Magazine Cut-off Date for articles, letters and For-Sales.

Thursday 9th:- Committee Meeting at the Greyhound Social Club, 140 Rookwood Rd. Yagoona (next to Potts Park).

Sunday 12th:- Robertson Classic Car Show at Robertson Railway Station, in the Southern Highlands. VWs 30+ years old wanted! Entry from 9:30am, \$10 to show your VW, or free general admission. \$5 raffle tickets to raise funds for Robertson Railway. Judging and Trophies to be confirmed. Country market stalls, vintage machinery, antique shops, food and drink stalls. **Join the Club VW Convoy at Uncle Leo's Caltex, Liverpool Crossroads, at 7:30am for 7:45am departure.**

Thursday 16th:- CLUB VW MONTHLY MEETING at the Greyhound Social Club, 140 Rookwood Rd. Yagoona (right next to Potts Park). Get the latest VW news and views, plus VW socialising, drinks, raffles, trivia and plenty of prizes. Lots of fun, all welcome. 8:00pm start.

Monday 27th:- Canberra General Meeting at the Canberra Labor Club, 16 Petrie Plaza, Civic, at 7:30pm.

May.

Thursday 7th:- Magazine Cut-off Date for articles, letters and For-Sales.

Thursday 14th:- Committee Meeting at the Greyhound Social Club, 140 Rookwood Rd. Yagoona (next to Potts Park).

Thursday 21st:- CLUB VW MONTHLY MEETING at the Greyhound Social Club, 140 Rookwood Rd. Yagoona (right next to Potts Park). Get the latest VW news and views, plus VW socialising, drinks, raffles, trivia and plenty of prizes. Lots of fun, all welcome. 8:00pm start.

Saturday 23rd:- NW Nationals Supersprint at Sydney Motorsport Park, Eastern Creek (South Circuit). Our first time at this famous track! VW racers wanted, air AND water-cooled. Stock is OK. CAMS licence and helmet required. Phone Rudi Frank on 0418 442 953 for more information.

Sunday 24th:- VW NATIONALS 2015 at Fairfield Showgrounds. Australia's biggest

Volkswagen show - 45 show categories, trade stands, swap meet, new VW display, kids' rides, Club shop, German dancing, great food and drink, VW fun all day. Phone David Birchall on (02) 9534 4825 for more info, or see www.clubvw.org.au

Monday 25th:- Canberra General Meeting at the Canberra Labor Club, 16 Petrie Plaza, Civic, at 7:30pm.

June.

Thursday 4th:- Magazine Cut-off Date for articles, letters and For-Sales.

Thursday 11th:- Committee Meeting at the Greyhound Social Club, 140 Rookwood Rd. Yagoona (next to Potts Park).

Thursday 18st:- CLUB VW MONTHLY MEETING at the Greyhound Social Club, 140 Rookwood Rd. Yagoona (right next to Potts Park). Get the latest VW news and views, plus VW socialising, drinks, raffles, trivia and plenty of prizes. Lots of fun, all welcome. 8:00pm start.

Monday 29th:- Canberra General Meeting at the Canberra Labor Club, 16 Petrie Plaza, Civic, at 7:30pm.

August.

Friday 28th - Sunday 30th:- VW Winter Break 2015 at Sawtell. Participate in activities or just veg out! Bookings for cabins and campsites need to be made ASAP. Phone the caravan park on 1800-729835 to make your booking - tell



Trades and services directory.



Original Equipment Manufacturers & Designers for the Motor Industry



Volkswagen parts

Warwick Blackwood
National Sales Manager

99-105 Boundary Road
Peakhurst NSW 2210
Sydney Australia
www.hasmot.com

Tel: +61 (0) 2 9533 2722
Fax: +61 (0) 2 9153 6033
Mob/Cell: +61 (0) 411 131 205
Email: gillian@hasmot.com

them you are with the VW people. All VWs welcome! Phone Steve Carter on 0490 020338 for more info.

Marktplatz.

All ads should be emailed to editor@clubvw.org.au

Classifieds are free for Club Veedub Sydney members, and \$10.00 for non-members. All ads will be published here for two months.

All published ads will also appear on our club website, www.clubvw.org.au. Photos can be included on the website but not in Zeitschrift. All ads will appear in Zeitschrift first so our members have first chance to see them. They will then be transferred to the club website on the third Thursday of the month.

Non-members please post us a cheque or money order for \$10.00, payable to: Club Veedub Sydney, PO Box 1340 Camden NSW 2570.

New Ads.

For Sale:- Hi there I'm about to advertise my pride and joy for sale and thought I'd let local VW clubs know first! She's a **1967 Karmann Beetle Cabriolet**, and I have owned her for over 20 years. Originally from Wolfsburg factory itself. She came with me to Australia when I moved here in 1998. She's a 1500, and has recently been fully serviced with full suspension and brake rebuild, carbie rebuild, dress up kit, full chrome kit, new clutch, new exhaust. There is some bodywork left to do, mainly bottom of doors. I'm taking pictures today to advertise online. If any of your members are interested, they can get me (Izzy Coleman) on 0413 459495, or email isobelcoleman@bigpond.com

For Sale:- Beautiful little **1962 model Volkswagen Beetle** in great working condition! Fully registered (6/5/2015) rego plate BF28SK. Odometer reading of 29000 miles, engine was upgraded with a later model VW 1300cc engine, front driver and passenger seats replaced by Mitsubishi bucket seats,

Trades and services directory.

Unit 1
11B Harp Street
Campsie NSW
Australia 2194

Tel: 02 9789 1777
Fax: 02 9718 8704



KOMBI **GHIA** **TYPE III** **BEETLE**



WWW.VINTAGEVEEDUB.COM.AU



Est. 1980



VW & Audi SPECIALISTS

1st Class Mechanical
Repairs to Volkswagen,
Audi and all Japanese cars

RON CROFT, M.I.A.M.E.

PADSTOW INDUSTRIAL ESTATE
C20/78 GIBSON AVENUE
PADSTOW NSW

PH: (02) 9774 3340

brakes have been upgraded by fitting an aftermarket VH44 brake booster. Asking Price \$7,700 (negotiable) Please contact me if interested on 0407 090577 or email keegan.yeak@gmail.com Regards, Keegan Yeark

Wanted to buy:- Portarack roof rack to suit early model Beetle. If you can help, please phone David on 0409 593443 or email jndhendo3@bigpond.com

For Sale:- 2011 Volkswagen Jetta 103TDI – 6 speed DSG (Comfortline) in Candy White. Absolutely immaculate. Has been a great family car with 6 air bags, alloy wheels, cruise control, power options, as well as front and rear park sensors. Owner now looking to upgrade to a bigger car for the growing family. This vehicle is a one owner, is well maintained and has full Volkswagen service history (all books included).

*Registration is valid until December 2015 offering you great value and peace of mind.

*Economical diesel.

*Fully Serviced by Volkswagen.

*2 Keys included.

*85 000 kilometres (Mainly M4 ,Blaxland to Westmead)
\$16999 ONO

Contact Carl on 0417 471137 or email carl@ecopac.com.au

Trades and services directory.

Trades and services directory.

IMAGINE  
THE BIGGEST & BEST DISPLAY IN AUSTRALIA OF
NOS & NLA STOCK
REPUTED TO HAVE THE LARGEST STOCK IN THE WORLD
NOS = NEW OLD STOCK
NLA = NO LONGER AVAILABLE

Volkswagen Autos 

PHONE FOR PRICES & STOCK
(02) 9688 2933 6 DAYS
FULL MAIL ORDER SERVICE
FAX: (02) 9896 3291

20 JOYCE ST PENDLE HILL NSW 2145

KLAACK MOTORS

All Mechanical Repairs & Restoration Work

 **★ Family Owned And Operated For Over 40 Years ★**

Distributors of Performa Fuel 

Ph: (02) 9724 5901 or (02) 9727 2057 Fx: (02) 9723 5250
2A Lackey Street, Fairfield, NSW 2165

Stan Pobjoy's Racing Engineering P/L

All engines are precision machined and personally built by Stan Pobjoy, guaranteeing you professional engine build quality and exceptional performance.
Power your VW with a Pobjoy engine today!

02 6654 3694

Stan Pobjoy's Racing Engineering Pty Ltd
1252 Orara Way, Nana Glen, Coffs Harbour NSW 2450

ANDREW DODD AUTOMOTIVE

THE ENTHUSIAST VW SPECIALIST

Specialising in:
Engine Reconditioning, Brakes, Front End Work, Servicing & Modifications to VW Beetle, Kombi, Type 3, Golfs & Passats.

40 YEARS VOLKSWAGEN EXPERIENCE

We are located at:
Units 54 & 55/2 Richard Close
North Rocks (Off Loyalty Rd)

PH: (02) 9683 2184

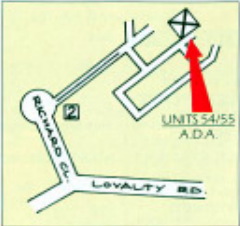

Wanted:- 15 x 5½ 4 stud VW rims. If you can help please SMS 0409771822 or see Norm Robertson at the club meeting. Thanks

2nd Month Ads.

For Sale:- I have a blue 1993 VW Golf Cabriolet that I am looking to sell. It is slightly damaged, however, I thought someone in the club may like to purchase it as a project to do up or to use as spare parts as they are hard to come by (it is only some sections of the body that are damaged, no mechanics. The car runs fine, has sports suspension and several other upgrades. May someone please be in touch with me should any members be interested or have a the same model and might be interested in my offer. Price \$1800 ono. Please contact Miss Victoria Davies on 0406 383205 or email victoria@davies.ws

For Sale:- 1997 VW Golf VR6 (Built June 1996) Manual 2.8 VR6 engine. Grey with black VW emblem on front doors. 245XXX km, owned since 2011. Much loved and cared for, owned by VW enthusiast. MSD coil pack, 10mm leads, K&N air filter, exhaust, Bilstein suspension (Neuspeed springs), leather, new cooling system (replaced parts over time of

ownership), serviced every 5000 km, new tyres (only have 500 km on them), cold A/C, bonnet bra. \$5500 ono. Selling due to purchase of new car. Sad to see her go. If interested, or for photos call, text or email Lachlan 0432 581805 lachieh@hotmail.com

For Sale:- Rebuilt VW 1776cc motor. Suit all models. \$1900. Contact John Ladomatos on 0449 236 076 for further details or email johnladomatos@y7mail.com

For Sale:- 1969 Type 34 Karmann Ghia Coupe. Believed to be the last Australian-delivered, right-hand-drive numbered Karmann Ghia, and by Lanock Motors St Leonards. Last year of series, matching numbers confirming a year model of 1969, original maintenance card, instruction manual and tools. Older glass-out restoration with new barrels in 2007, low mileage on replaced front brake callipers, shock absorbers and tyres. Third owner in 8 years, always under cover, original plates on hold, has become a work of art as not being used. Cover car April 2009 Zeitschrift. Worth an inspection at \$27,000. Phone Brad Robinson on 0419 223003 or email carmen.robinson@bigpond.com

Trades and services directory.



Jan Eveleens
Director

Bulkheads and security screens for VW vans

22 Ellen Street
Rozelle, NSW 2039
Australia

M 0414 26 33 33
F 02 8078 0641
info@motexion.com.au

www.motexion.com.au

Trades and services directory.



Camden GTI Performance are proud to present a special offer to all Club VeeDub Sydney members



FREE Diagnostic Computer Scan
5 minute Physical Diagnosis

Come and visit our brand new workshop – purpose built to service your watercooled Volkswagen and Audi vehicles.

We supply OEM and genuine German parts. Our specialist trained VW and AUDI technicians can fit any part. Using factory VCDS diagnostic software, we can repair, modify and service your German vehicle.

Typical late model oil and filter service: \$240

*Using synthetic oil, German filters,
30 point safety check and VCDS Scan*

Typical early model oil and filter service: \$165

*Using mineral oil, German filters,
30 point safety check and VCDS Scan*

Contact us on: (02) 4627 3072 or 0423051737

Or call in at: **Unit 20/6 Badgally Road,
Campbelltown, NSW, 2560** (Just off Blaxland Road)

We also stock a massive range of late model VW/Audi new and used parts in our parts centre!

WOLFSBURG MOTORS
Automotive Engineers

SJIRK BANGMA **JAN BANGMA**

38-40 Princes Highway • St. Peters, NSW, 2044
Tel: (02) 9519 4524 • Fax: (02) 9519 5575
Email: wolfsburg@tpg.com.au

AUSTRALIAN VW PERFORMANCE CENTRE

Australian VW Performance Centre is located in Croydon South, about 30 minutes east from the Melbourne CBD, close to Ringwood end of Eastlink. If you find yourself unable to contact us during business hours, please do not hesitate to email us with any enquiries you have.

www.vwperformance.com.au

Address: 29 Research Drive, Croydon South, Victoria, 3136

Phone: (03) 9761 4540 or (03) 9761 7917

Fax: (03) 9761-6216

Email: avwpc@vwperformance.com.au

INSURANCE FOR MOTORING ENTHUSIASTS

CALL 13 46 46
SHANNONS.COM.AU

SHARE THE PASSION

96 Toombul Rd
Northgate QLD
Australia 4013

MICK MOTORS

Ph +61 07 3266 8133
Fax +61 07 3260 5179
mick@mickmotors.com.au

Volkswagen Spare Parts

Lorenze

VW Genuine Parts from 1960-1974 model Beetles and Kombis. Engine overhaul parts, main bearings (STD and oversize), conrod bearings, cylinder heads, clutch parts, gearbox mountings, tail pipe and damper kits, blinker switches, starter motors, generators, alternators, and many more hard-to-get original NOS VW parts.

Northmead
(02) 9630 1048

Trades and services directory.

Trades and services directory.



NORTH ROCKY MECHANICAL
GET BACK ON THE ROAD, FAST

Contact info

Address: North Rocky Mechanical
43 Quinn Street,
North Rockhampton QLD 4701

Phone: (07) 4922 0111

Email: northrockymechanics@bigpond.com



Licence No.: 48315
ABN 90 146 466 864

Essential Smash Repairs

Paul Silvestro

M: 0419 649 815
P: (02) 9624 4660 F: (02) 9674 5156
E: paul@essentialsmash.com.au
A: 71 Powers Road Seven Hills NSW 2147
W: www.essentialsmash.com.au



Dave's Motion Racers

Get right into the action with racing motion simulators. Choice of rally and tarmac games, they suit drivers 1.4 to 1.9m tall and up to 110kg driver. Hire for parties, gatherings or just for fun



email for hire rates and conditions
ziltoid@optusnet.com.au

0432 211870

www.facebook.com/davesmotionracers



MOUNTAIN mechanics

Your Mobile Mechanic & Volkswagen Specialist

M: 0418 426 487 T: 4758 6032
adam@mountainmechanics.com.au
www.mountainmechanics.com.au
PO Box 32 Hazelbrook NSW 2779

Club Veedub Sydney Membership / Subscription Form.

New Member: Renewal:

Name:

Address:

State: Postcode:

Email:

Phone: (BH)

(AH)

(Mob)

Do you want to participate in CAMS motor sport? NO YES

Which of the following activities are you interested in? Please number in order:

- Cruises and observation runs
- Show n Shines, Concours
- Swap meets (VW parts)
- Social days and/or nights out
- Drag or track racing
- Meetings and tech talks
- Other (you tell us!):

Trades and services directory.

Trades and services directory.

BEST EXHAUST
THE WORLD'S BEST EXHAUST SYSTEMS
ABN 70 136 483 480



**FERRARI - PORSCHE
MASERATI - AUDI
ALFA ROMEO - FIAT
MERCEDES BENZ
LAMBORGHINI - VW
BENTLEY - BMW - JAGUAR**

see us at www.bestexhaust.com.au

Club Veedub Merchandise
For club polo shirts, jackets, hats, mugs, etc.
**Contact Raymond Rosch
(02) 9601-5657**

Club VeeDub Membership, Sponsorship and Merchandise payments can be made securely online via PayPal. You don't need an account but there is a small fee for the service. Please visit our web site at www.clubvw.org.au or email Raymond at sales@clubvw.org.au for more information.



CLASSIC VEE-DUB
Pty/Ltd

www.classicveedub.com.au

36 Bridge St.
Rydalmere
2116 N.S.W
Sydney Australia

phone: (02) 9638 4200
fax: (02) 9638 4266
George: 0412 434 762

Wanted:



Your business ad in this space. The cost for 11 months is \$110 - this does not include the VW Nationals issue. Post your business card and a cheque for \$110 to the Secretary, Club Veedub Sydney, PO Box 1340, Camden NSW 2570

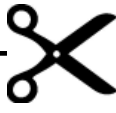

Club Veedub Sydney Membership / Subscription Form.

Please tell us about your Volkswagen(s):

Year	Model	Engine Size	Rego No.	Colour

Please enclose a cheque or money order for \$45.00, payable to Club Veedub Sydney, and post it with this form to:

**Club Veedub Sydney,
PO Box 1340
Camden NSW 2570**

You will receive 12 issues.

2015 Scirocco cheaper.

The 2015 Volkswagen Scirocco R has arrived in Australia with a new price tag that's \$2000 lower than before.

The updated Scirocco R costs \$45,990 in six-speed manual form and \$48,490 when equipped with the six-speed dual-clutch automatic DSG (both prices before on-road costs).



The new pricing positions the Volkswagen Scirocco R just \$4000 above the Golf GTI, bang on with the DSG-only GTI Performance and \$6000 below the AWD Golf R.

The price cuts come despite the introduction of a number of new features.

The updated model gets fresh styling, headlined by a redesigned grille, larger lower air intakes, and revised bi-xenon headlights and LED daytime running lights at the front; matt chrome door mirrors and 19-inch 'Cadiz' alloy wheels down the sides; and new LED tail-lights, a gloss black diffuser and a tailgate badge boot release at the rear.

Interior additions include a dash-top instrument binnacle with oil temperature, stopwatch and boost gauge dials, a new multifunction R leather steering wheel, satellite navigation, reverse-view camera, front parking sensors (complementing the existing rear sensors), 20Gb music storage, piano black trim elements, and black and grey cloth/alcantara upholstery.

Scirocco R coupes delivered to Australia miss out on the new 206 kW/350 Nm 2.0-litre four-cylinder engine tune that's available in Europe, instead making do with the same 188 kW/330 Nm outputs as before.

While that peak power figure continues to be produced at 6000rpm, the 2015 model's peak torque is available across a marginally broader band (now 2400-5200rpm, up from 2500-5000rpm).

The updated car's 0-100 acceleration claims are unchanged (6.2 seconds in the manual, 6.0sec in the DSG), and while the manual's combined cycle fuel consumption carries over at 8.1 litres per 100 kilometres, the DSG is now 2.4 per cent more efficient than before at 8.0 L/100 km.

Amarok update.

Details of the 2015 Amarok range have been announced, with Volkswagen Australia increasing equipment and specification levels for its diesel-powered range while also axing the existing petrol version.

The Volkswagen Amarok was previously available with the TSI300 engine (a 2.0-litre turbocharged petrol with 118 kW and 300 Nm, hence its moniker), which was the entry point into the ute range, priced from \$24,490 plus on-road costs for the single-cab, cab-chassis 2WD version. The TSI300 was also available in the \$25,990 pick-up 4x2 model, as well as the dual-cab 4x2 cab-chassis (\$31,090) and the 4x2 dual-cab ute (\$32,590).

However, Volkswagen has now announced a revised, diesel-only line-up, with 4Motion all-wheel-drive now available across a broader range of models.

The new entry-level model is the dual-cab 2WD manual, priced at \$31,490 for the cab-chassis or \$32,990 for the ute version. This entry-level specification now comes with standard cruise control and Bluetooth connectivity, along with an updated stereo system and body-coloured front bumper.

Buyers can opt for the Amarok Core Edition with 4Motion all-wheel-drive, which includes the revised colour-coded bumpers and new 16-inch alloy wheels with Pirelli Scorpion all-terrain tyres.



Amarok Trendline models now receive standard front and rear parking sensors and 17-inch alloy wheels. An optional media system with satellite navigation and a reverse-view camera is now available on Trendline models, and both the driver and front passenger seats can also be had with optional lumbar adjustment. Trendline models can also be had with the (no-cost) optional comfort suspension setup, which decreases load capacity (by roughly 200 kilograms) but improves ride comfort.

The 2015 Amarok Highline now gains a standard reverse-view camera, automatic wipers and headlamps, and lumbar support for the driver and passenger seats. Highline variants can now also be optioned with bi-xenon headlights.

The flagship Amarok Ultimate has risen to take the spot of the most expensive lifestyle ute (not including the Toyota LandCruiser 70 Series), with the automatic model now \$65,290 plus on-road costs. However, it has gained more gear, mirroring the Highline equipment upgrades but also adding leather interior trim and 19-inch wheels, as well as bi-xenon headlights with LED daytime running lights.

All VW Amaroks are powered by a 2.0-litre turbo diesel in varying states of tune.

The engine options are as follows: TDI340 has 103 kW/340 Nm and is available only with a six-speed manual transmission. The TDI400 has 132 kW/400 Nm and comes



with a six-speed manual; the TDI420 has 132 kW/420 Nm and comes with an eight-speed automatic only.

2015 Volkswagen Amarok pricing (plus on-road costs):

Single-cab:

TDI400 4WD manual cab-chassis – \$35,490

TDI400 4WD manual ute – \$36,990

TDI420 4WD auto cab-chassis – \$38,490

TDI420 4WD auto ute – \$39,990

Dual-cab:

TDI340 2WD cab-chassis manual – \$31,490

TDI340 2WD ute manual – \$32,990

TDI420 2WD cab-chassis auto – \$36,490

TDI420 2WD ute auto – \$37,990

TDI400 4MOTION Core Edition cab-chass man – \$41,490

TDI400 4MOTION Core Edition ute manual – \$42,990

TDI420 4MOTION Core Edition cab-chass auto – \$44,490

TDI420 4MOTION Core Edition ute auto – \$45,990

TDI400 4MOTION Trendline cab-chass manual – \$45,490

TDI400 4MOTION Trendline ute manual – \$46,990

TDI420 4MOTION Trendline cab-chassis auto - \$48,490

TDI420 4MOTION Trendline ute auto – \$49,990

TDI400 4MOTION Highline ute manual – \$52,490

TDI420 4MOTION Highline ute auto – \$55,490

TDI400 4MOTION Ultimate ute manual – \$62,490

TDI420 4MOTION Ultimate ute auto – \$65,490

VWs coming in 2015.

Here are details of the new and updated Volkswagen models launching in Australia in 2015.

Volkswagen Jetta – February



An updated version of the slow-selling Volkswagen Jetta mid-size sedan will arrive early in the year, likely bringing with it a new price tag and revised equipment.

The Jetta also sees a minor facelift that makes it appear more like the current Passat, with revised headlights and a new front bumper.

Engine options may include a new 1.4-litre four-cylinder turbo with 103 kW of power (as used in the Golf), but the Jetta could also persist with its existing 118TSI twin-charged petrol engine alongside a more powerful 155TSI turbo 2.0-litre and a 2.0-litre diesel.

Stay tuned for pricing and specs soon.

Volkswagen Touareg update – Q1

A facelifted version of the Volkswagen Touareg is expected to hit our market in the first quarter of 2015.

The revised model gains a range of changes, including updated diesel engines (150TDI with 150 kW/400 Nm and V6 TDI with 193 kW/550 Nm) with lower fuel consumption. This is partly due to a new coasting function that disengages the standard eight-speed auto when no acceleration is needed.



Further changes include revised exterior styling, new interior materials, retuned suspension, a 'stop and go' function for the adaptive cruise control system, and a new mobile online services feature with integrated Google Street View, Google Earth and Google points of interest searches.

Stay tuned for pricing and further specifications as they come to hand.

Volkswagen Polo GTI – Q2

The Volkswagen Polo GTI will return with a manual gearbox in the second quarter of 2015.

The new GTI may look similar to the existing model, but there are myriad changes – including that new manual



transmission – and a new 1.8-litre four-cylinder turbocharged engine with 141 kW and 320 Nm. For those who wish to let the car do the driving, there's a seven-speed dual-clutch auto option, too.

A revamped interior includes a larger media screen than in the standard Polo range, meaning it should include satellite navigation and a reverse-view camera. Specifications are currently unclear, though.

Pricing for the entry manual model is expected to drop to a new baseline, possibly tackling the Ford Fiesta ST at \$25,990 plus on-road costs.

Volkswagen Golf Alltrack – Q3

VW doesn't yet have an SUV to sit between its Tiguan and Touareg models, and while there is a Passat Alltrack to help quench the thirst of SUV buyers, there'll soon be a smaller alternative in the form of the Volkswagen Golf Alltrack.



The Golf Wagon-based high-rider has all the looks to go with its all-wheel-drive underpinnings, including a rugged body cladding package, underbody bash plates and sills, and uniquely designed alloy wheels.

Engine and drivetrain details are still to be confirmed, though it's likely there will be a turbo petrol and turbo diesel offering.

Expect pricing to be slightly higher than the regular Golf Wagon, which ranges from \$25,540 to \$36,340 plus on-road costs.

Volkswagen Passat – Q4

In arguably VW's biggest local launch this year, the newly redesigned Volkswagen Passat will arrive about a year after its European debut. But based on impressions of the mid-to-large sedan and wagon following the 2014 Paris motor show, it will be worth the wait.

The new Passat will be available in 132TSI guise with a 1.8-litre turbo petrol engine with 132 kW/250 Nm, and a



135TDI turbo diesel offering 140 kW/400 Nm from the same displacement. Those models will both be front-drive, with seven- and six-speed dual-clutch autos respectively.

There may be a range-topping 176 kW/500 Nm 176TDI 4Motion twin-turbo diesel, and/or a petrol-powered 206 kW/380 Nm (the same engine as in the Golf R). A 162 kW version (same as is used in the Skoda Octavia RS) could also arrive.

The Passat currently ranges from \$38,990 to \$59,240 plus on-road costs, though that high-end price relates to the V6 4Motion model.

Volkswagen Caddy – Q4

An updated version of the top-selling Volkswagen Caddy small van range should hit local showrooms towards the end of 2015.



The new model is set to see some major styling changes over the existing model, with a revamped front end, revised rear and updated interior.

Expect to see the production car unveiled by mid-year, when we'll report on it further.

Volkswagen T6 Transporter – Q4

In the other big launch for 2015, there'll be an all-new Volkswagen Transporter van available to buyers by the fourth quarter of this year.

The new T6 van range will likely see improvements in terms of its equipment, while a heavily revised exterior (but with the traditional boxy back-end, improved for better capacity and cargo holding ability) will help the VW fight against the benchmark-setting Ford Transit, and hopefully pull back some local sales from the crude Toyota Hiace and Hyundai iLoad.

We will report on the much anticipated T6 Transporter as soon as news comes to hand.



VW's after-sales 'inadequate.'

With recent recalls and poor customer satisfaction ratings continuing to blemish the Volkswagen marque in Australia, the local division has conceded that investment into the group's aftersales and dealer networks has been inadequate.

Speaking exclusively with the CarAdvice automotive website, Volkswagen Group Australia communications general manager Karl Gehling said while there has been significant investment into aftersales and customer support, backing of dealers hasn't been to sufficient levels.



"We've invested a lot in our aftersales activities and our customer support and we've seen some significant improvements in our own internal measures and both externally as well. And we continue to make our customer satisfaction a high priority in our activities," Gehling said.

"I think our brand has grown very quickly over the last few years, so we've seen a rapid increase in the size of our car park and we probably haven't invested as adequately in our aftersales support to deliver the same commensurate increases in aftersales coverage that we should have."

Despite improving 22 points in the latest JD Power Australia Customer Service Index Study – the third-largest improvement of any brand – Volkswagen remains dead last, a position it's held for the past three years straight.

Rating overall customer satisfaction with vehicle service experience at authorised service centres based on service quality, vehicle pick-up, the service advisor, service initiation, and service facility, the 2014 study was topped by Mazda for the second consecutive year.

Asked when existing investment is likely to net significant performance improvements, Gehling said it's dependant on how competitors change as well.

"But we're continuing to work at it..."

"As with any product you can have issues and we know when/if there's a problem, and we can identify it, we can obviously deal with that through our dealer network.

"Obviously, the dealers are our point of contact with our customers – they are the front line – and we support our dealers through a number of measures in terms of ensuring that we provide training and aftersales support and our job is to ensure that we work closely with dealers to not only improve the level of service that they can provide through our own process but we also want to make sure that they share the same sort of customer drive that we have to ensure that we deliver the best experience we can."

Volkswagen Group Australia made headlines in 2013 when it recalled almost 34,000 Audi, Skoda and Volkswagen models due to a defect with the seven-speed dual-clutch DSG transmissions. VW's positive actions to address the problem confounded those who predicted that sales would slump; in fact VW sales have remained at around 54,800 for the last three years. VW's sales for 2014 declined only by 0.2% in a market that contracted by 2% overall, and the Golf recorded its highest Australian sales ever, 19,178.

The Australian dealer body continues to expand, with new and rebuilt Sydney premises opening at Artarmon, Blacktown, Five Dock, Rockdale and Castle Hill in the last few years. However there are still many gaps, with no VW dealer existing in the Bankstown, St George or Eastern Suburbs areas since the early 1980s, and only a tiny showroom in the Sutherland Shire. In the 1960s VW had 33 dealerships in Sydney, with half the population and half the VW sales of today.

Golf R Touch.

At its first ever Consumer Electronics Show, Volkswagen unveiled its Golf R Touch concept, which packs an array of high resolution screens, gesture sensing technology and capacitive buttons into the cabin.

As far as the drivetrain goes, it's understood that the Golf R Touch features the same 206 kilowatt-packed 2.0-litre turbocharged motor hooked up to an all-wheel drive system as other Golf R models.

It's inside the cabin where all the action is. The upper portion of the control stack, as well as the central vents, are replaced by a glossy 32.5 cm 2560×1700 touchscreen. Below this is a multi-touch slider bar, underneath which is an 20.3 cm 800×480 touchscreen.



This screen, just ahead of the gear lever, is tasked with controlling the climate control and audio systems. It has been equipped with localised haptic feedback, so the driver can run their fingers along the screen to find the button they're looking for without looking away from the road; virtual buttons on this screen are pressure sensitive.

The final screen won't surprise anyone who has sat in a luxury car over the last few years, with a 32.5 cm 1920×720 display replacing the traditional analogue-style gauges.

A gesture sensor mounted in the ceiling just ahead of the sunroof allows the driver or front passenger to control certain functions, such as which track is playing, audio system volume and sunroof operation, with a wave of one's hand.

Practically all of the car's physical levers and dials, including the electric window switches, have been replaced by touch sensitive elements.

Strips of LED ambient lighting are strung out across the dashboard and door panels, and can be customised to almost any colour in the rainbow. The upper screen also features user customisable wallpapers and configurable home screen tiles.

Some of this high-tech gear may be headed into Volkswagen models in the near future, but officials on hand weren't keen on discussing what will turn up and which models may see it first.

Bigger Tiguan confirmed.

The next-generation Volkswagen Tiguan won't go on sale until 2017, but it will boast big changes including a longer wheelbase, seven-seat capability and a 500-litre-plus boot, Volkswagen of America has confirmed.

Volkswagen of America CEO Michael Horn spoke before the opening of the Detroit Motor Show, revealing that the next Tiguan will be built in North America as well as Europe.



"Last year we announced the mid-sized CrossBlue SUV will be built. Now we have the decision to move the long wheelbase Tiguan here," Horn said.

"One thing would be built on our mid-sized MQB platform [CrossBlue], the other on our compact MQB platform [Tiguan], so the interior space is totally different."

Asked directly whether the next Tiguan would have a third row of seating, Horn answered, "yes."

"If you take for instance the third row," he continued, "[the] mid-sized SUV has up to best-in-class leg-room space and it has superior headroom space. The third row in the compact SUV is more for emergency for smaller children, so the comparison, if the family wants a true seven-seater they will not consider the compact SUV. We clearly keep them apart."

The CrossBlue will be built in the US in 2016, however, while the Tiguan will lag one year behind, "due early-mid 2017", according to Horn.

The VW US boss also "absolutely" recognises that the current 4.4-metre-long Tiguan has been criticised for offering

a small 395-litre boot, something which the company clearly plans to address for the next-generation model.

"Ask me? Something around 500 litres or something," Horn tells as the engineering target for boot space for the next Tiguan.

"The Tiguan will be roughly 4.7 metres long. The mid-sized SUV will be more than 5.0 metres long."

Despite identifying the new Tiguan as a long-wheelbase model, Horn insists only one wheelbase will be used, with seven seats likely optional.

The current Tiguan will be nine years old by the time the new model comes to market, something Horn doesn't seem too concerned about when it was asked whether the project was delayed.

"Not too much [delay]," he answered. "Europe get the project at the same time. We had our experiences with the Sharan [people mover], which was more than 15 years in the market."

"Volkswagen is sometimes late, but we come very strong and we hit it hard".

Australian introduction of the new Tiguan will shortly follow after its introduction in Europe.

Cross Coupe GTE.

The Volkswagen Cross Coupe GTE concept been unveiled on the eve of the North American International Auto Show, offering the latest preview of the brand's future mid-size SUV model series.

The Cross Coupe GTE is an evolution of the CrossBlue Coupe concept that debuted in Shanghai last April, which was itself a spin-off of the seven-seat CrossBlue concept from last January's Detroit show.

The new concept shares design cues with Volkswagen's Golf GTE and Passat GTE production cars, sporting restyled headlights that flow into a bold two-slat grille, a revised lower front bumper with a stylised intake blade, newly flared rear wheels arches, reshaped tail-lights and rear bumper, and cleaner bodywork that trades the earlier concept's hard-wearing plastics and metals for body-colour panels.



New Grand Pacific Glacier blue paint and polished 22-inch alloy wheels inject extra freshness to the exterior, which boasts proportions similar to the BMW X6 and Mercedes-Benz GLE Coupe.

The five-seat cabin also gets a design language upgrade, highlighted by the use of consistent horizontal structures,



seamlessly integrated displays and chrome elements, and interactive gesture controls.

Powering the Volkswagen Cross Coupe GTE concept is a 3.6-litre V6 and two electric motors. The direct-injection petrol engine produces 206 kW and 350 Nm, while the electric motors – positioned on the front and rear axles – have outputs of 40 kW/220 Nm and 85 kW/270 Nm respectively.

Volkswagen claims a total hybrid system output of 265 kW and 500 Nm, helping the Cross Coupe GTE from 0-100 km/h in 6.0 seconds and on to a top speed of 209 km/h, while its 14.1 kWh lithium-ion battery pack allows it to travel up to 32 km on electric power alone.

A six-speed dual-clutch transmission can send power to the front, rear or all four wheels and facilitates five distinct driving modes: E-mode, Hybrid, GTE, Off-road, and Battery Hold/Battery Charge.

Drivers can also select between four driving ‘profiles’, On-road, with Comfort and Eco sub-modes; Off-road, with Gravel, Rocks, Sand and Sludge sub-modes; Sport; and Snow.

Any production version of the 4847mm-long Cross Coupe GTE concept is expected to slot beneath the larger seven-seat CrossBlue concept in Volkswagen’s next-generation SUV range that will roll out progressively over the coming years.

With Australia’s passion for SUVs in all forms showing no signs of slowing, it’s very likely that Volkswagen Australia will quickly introduce the CrossBlue and Cross Coupe to our market.

New bigger VW sedan?

AutoBild magazine in Germany reports that that Volkswagen is currently considering options for a new sedan to fit above the Passat, in its various guises, but below the second-generation Phaeton.

The two primary markets for this Passat-Phaeton-splitting sedan will be China and the US. In both of these markets the sedan body shape is popular and large cars still fare relatively well.

What mix of components will form the basis of this new car has yet to be determined. According to the German magazine, there are two scenarios that Volkswagen is currently considering.

The first option involves using a stretched version of the upcoming second-generation North American Passat (a

completely different and somewhat cruder vehicle than the more sophisticated Euro Passat sold in Australia). This car is scheduled to start rolling out of the company’s plant in Chattanooga, Tennessee from 2017.

An uber-Passat built this way would have an attractive sticker price, and would be relatively cheap to design and engineer. One potential sticking point is the lack of a suitable VW V6 engine.

All of the uber-Passat’s competitors in the US — such as the Toyota Avalon, Chevrolet Impala, Ford Taurus, Hyundai Azera and Nissan Maxima — all feature V6 motivation in a majority of specifications.



Volkswagen has stopped development work on the narrow angle VR6 engine due to tightening emission laws in Europe, so a replacement motor is required. A possibility suggested by AutoBild is to utilise Audi’s 3.0-litre V6.

The other option is to use the Audi A6 as the basis for the new car. The advantages of this method include a selection of ready-to-use drivetrain options, including four- and six-cylinder diesel and petrol motors. This has some historical resonance; the original Passat was based on the predecessor of the Audi A4, then known as the Audi 80 (Fox). The larger A6 could be considered the descendent of the Audi 100.

An A6-based vehicle will be more expensive to build and sell, but this, in its own way, would make it a better fit for Europe. If Volkswagen were to market the uber-Passat in Europe, a wagon body style would almost certainly be required, but this would not be a problem as Audi already makes wagon versions of the A6.

With Australians turning away from large sedans in recent years in favour of large SUVs, it’s unlikely that the uber-Passat would be sold here. Volkswagen Australia has never considered importing the large Phaeton, which has been available in Europe (and sometimes the USA) since 2003.

VW-BMW electric outlets for USA.

Volkswagen and BMW will install a set of almost 100 fast charging stations across the USA by the end of 2015.

The concerted effort by the two German automakers will expand the existing charging station network operated by Chargepoint. The new charging facilities will be located along the west coast and in the heavily populated north-eastern corner.

On the west coast the stations will be placed on the interstate highways that link Portland, Oregon with San Francisco, Los Angeles and San Diego in California. For the other side of the country, the companies will fund stations on the main routes between Boston, New York City and Washington, DC.

It's expected that the majority of these new stations will be adjacent to restaurants, rest stops, shopping centres and other facilities. Some stations will be in or near city centres, but most will be located along the interstate highways network. Charging centres setup along highways will be spaced roughly 120km apart.

According to BMW and Volkswagen, each new charging location should feature up to two 50kW DC or 24kW DC fast charging points, which, it's claimed, can bring a BMW i3 or Volkswagen e-Golf up to a charge level of 80 percent within 20 minutes. Every station will also include an array of 240V Level 2 recharging points.

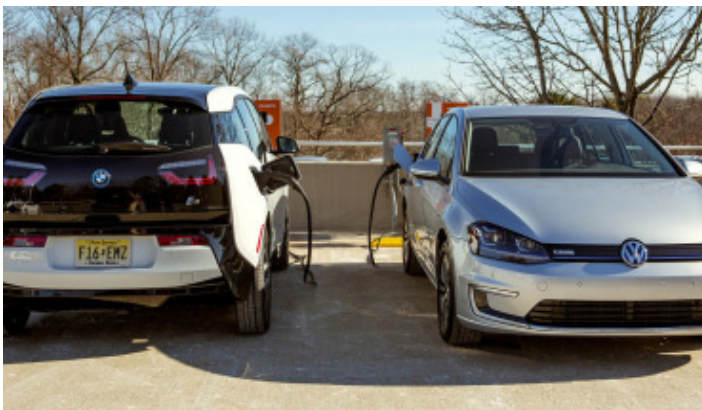

The German companies' concerted effort to roll out fast charging stations is part of an effort to aid long distance travel for owners of electric cars, specifically those manufactured by BMW and Volkswagen. It should be noted that other electrified cars that support DC fast charging or SAE combo fast charging socket can also be charged at these new erected stations.

Toyota outsells VW – just.

Toyota has just edged out Volkswagen for the 2014 global sales crown, by just 90,000 vehicles.

In figures released last week, Toyota Motor Corporation sold a total of 10.23 million vehicles throughout 2014, with 9.15 million cars attributed to Toyota (up two per cent). 915,000 vehicles were sold under the Daihatsu brand (up five per cent), while 168,000 Hino trucks (up four per cent) were delivered to customers. Lexus' figures weren't broken out and have, presumably, been rolled into Toyota's numbers.

Toyota is forecasting that its global sales in 2015 will slip by around one per cent to 10.21 million.

Coming in second place for 2014 was Volkswagen AG with total sales of 10.14 million vehicles. All of the group's major passenger car brands increased their sales. VW accounted for 6.12 million of that total, with Audi chipping in with a profitable 1.74 million vehicles (up 10.5 per cent).



Czech marque Skoda sold 1.04 million cars (up 12.7 per cent), while Seat moved 390,500 units (up 10 per cent), and Porsche retailed 189,800 cars and SUVs (up 17.1 per cent).

The only decline came from Volkswagen's commercial vehicle operation (Volkswagen, Scania and MAN), which was down 5.4 per cent to 646,500 vehicles.

Both the Volkswagen Group and Toyota broke through the 10 million sales mark for the first time in a calendar year.

General Motors claimed the final podium place with a total of 9.92 million vehicles sold throughout 2014. Of that number, 4.79 million vehicles wore Chevrolet badges (down 1.4 per cent), while Opel and Vauxhall combined together had a tally of 1.09 million (up 2.8 per cent). Propelled by strong sales in China, Buick notched up 1.17 million units (up 22 per cent).

Cadillac was down 3.8 percent to 263,782 sales in 2014, with local offshoot Holden managing to shift 106,092 vehicles (down 5.3 per cent).



VOLKSWAGEN MICROBUS



amazing carrying capacity with "go anywhere" ruggedness

Carries 9 people (including driver).

Plenty of leg room and head room . . . soft, comfortable seating . . . panoramic vision.

Wide Side Doors for easy entrance.

Ample luggage space . . . "out-of-the-way" storage for up to 16 average-size suitcases.

Rear luggage loading avoids passenger inconvenience.

Efficient Ventilation System can renew the total volume of air every minute.

Heater and De-frosting System is standard equipment, keeps occupants warm and comfortable even in extreme conditions of cold.

Air-cooled Engine won't freeze or boil . . . "oversquare" slow-ravving design, with cooled oil, gives exceptional life and freedom from service.

Independent 4-wheel suspension irons out bad roads . . . progressive rate springing gives stability . . . rugged strength and high ground clearance easily cope with worst conditions.

The smart choice for staff transport, school buses, hotels and holiday resorts, touring parties . . . wherever people and their luggage require fast, de-luxe transport at lowest cost.

The Toy Department.

Sometime ago we featured an article on the T2a 1/14 plastic scale model made in China by Dickie of Germany and sold in most Big W stores.

We featured how to very easily repaint these models in your very own original or customised colours.

In this edition we see how we can go to the next level by modify these into a fully functional remote control version.

First I had a bit of spare time over the Christmas break and my son gave me the idea of converting one his 4WD monster cars into a VW monster truck – basically it was a lot easier than I thought and by removing the existing chassis I was able to position the body perfectly on the existing chassis and even secure the body with some cable ties through the roof where the surf board roof rack holes were already positioned.



Basically a 10 minute job and then it was over to the garage for the new two tone blue / white paint work – looks great! and it goes great too!

Still feeling a little challenged I recalled at old Bar last year that a Kombi Club member who had successfully converted one to a remote control by using a donor chassis also from a Chevy found at Big W and looking at most other RC cars of a similar size or scale and with a bit cutting (hack saw and a Dremel cutting tool) you could successfully



transplant the chassis to give an authentic look fully functional remote control VW Microbus.

Any way Club member Joe Buttigieg and I admired the work done and went our way back to our respective sheds (caves) and set about the task of transplanting a donor Chevy chassis into a 1/14 scale VW Microbus.

Well here Joe's finished product, mind you I think we all agree that we need to send Joe on aspray painting course - but at the end of the day we both had a lot fun putting these together.



When it comes to paint I found that it best to keep away from expensive hobby acrylic paint or even motor vehicle paint – the best finish I found was from common every day spray paint as the application was more consistent



and gloss finish was most superior.

These VW models come with some period stickers and these are great for detailing the windows and surf boards that come with them.

Also I found painting the surf boards with spray paint gave them a more authentic look.

Away here are our finished products and for the movie length view of these great models in full operation I recommend you visit this u tube site <https://m.youtube.com/watch?v=YSXxh7j2EIU>

Tony Bezzina
kbezzina@bigpond.com





wigs and accessories and official festival souvenirs. You can even purchase an Elvis car licence card and replica stage suits which Elvis wore when he performed live.

Cooke Park is the place to be in the evening where the main stage comes alive with entertainment for everyone. Elvis impersonators come on stage one after the other singing all the Elvis songs and imitate all the Elvis pelvis movements that he did in days gone past.

The Main Stage in Cooke Park has three days of free entertainment. It started to sizzle on Friday morning and kept on rocking right through to Sunday the 11th January with all day entertainment including Elvis Tribute Artists, Rock 'n'Roll dance demonstrations, competitions and more.

Joe's Elvis adventures in Parkes.

As you all know in January I normally go to the Tamworth Country Music Festival, but this year I thought Mary and I would have a bit of fun and visit Parkes for the Elvis Presley festival. It officially started on Wednesday 7th and finished on Sunday 11th January, in honour of Elvis's birthday. He was born in Tupelo, Mississippi on 8th January 1935 – which means the King would have been 80 if he was still alive. But he died in 1977, aged only 42.

We left on Thursday morning at 6.40am and arrived in Forbes at 1.30pm(346 km). When I booked two months ago, all the venues in Parkes were booked out, many of them 12 months in advance. I was lucky to find a room at the Lakes Forbes Motel, only because someone had cancelled, and for \$109 per night, it was a bargain.

After settling in, we drove to Parkes (32 km) and just strolled around town, checking in all the Elvis memorabilia. Elvis Central in Clarinda St is where you go, where they stock Official Merchandise as well as a range of Elvis and Priscilla

During the day you could also go and see Elvis movies in some of the clubs hosted by Elvis impersonators and there were buskers in Clarinda St which was closed off for traffic from Friday to Saturday. Competitions include Miss Priscilla look-a-like and Elvis look-a-like both for adults and kids and also an Elvis Tribute Artist Competition "Tribute to the King".



The people staying in our Motel came up in the Elvis train from Sydney on Thursday, which had left Central station at 9.00am and arrived late at Parkes due to heating problems, about 7.00pm. One of the guests who saw my Kombi parked outside my room came to have a chat. He happens to be a proud owner of a 1975 Kombi, and his Maltese mate saw the sticker on the quarter window "Daz Maltese Cruizers". We spent a bit of time talking until the coach came to pick them up and take them to the Festival.

If I do it again next year, I will want to stay for the big street parade on the Saturday because I was told it's a cacophony of colour, sound and any and everything Elvis. Rounding out the parade will be the beautiful "Cars of the Era", several of these will be carrying the competition



winners including the newly crowned Miss Priscilla. On the last, Sunday, at Cooke Park main stage, they have the Renewal of Vows Ceremony which is a fantastic way for couples to show their true feelings for the one they love and cherish.

And in case you are wondering, yes Elvis did once drive a VW in one of his movies. He was more famous for buying lots of luxury Cadillacs, and he drove sports and racing cars in Viva Las Vegas, and Speedway. In 1968 he released his 28th movie, Live A Little Love a Little. The opening credits show Elvis zooming around in a Meyers Manx dune buggy. He did his own driving too. Later you could even buy a plastic scale model of Elvis's dune buggy. That movie only had four songs, but one of them was A Little Less Conversation that was remixed in 2002 and became a huge hit all over again.



Joe Buttigieg (he has left the building).

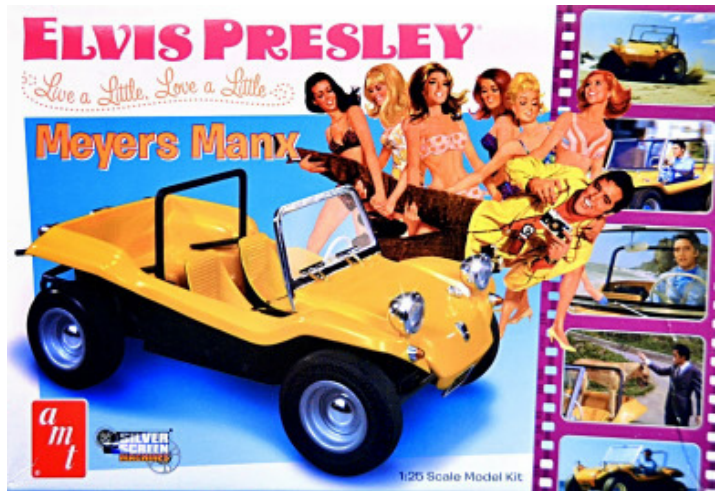

THIS CAR IS NEWS-



SO MUCH MORE— NO EXTRA COST

SEE ME AT

DENLO

MOTORS

126 PARRAMATTA RD., AUBURN
YX1208 YX1173

Phone for Home Demonstration or Catalogue



Club VeeDub turns 30!

Welcome to the 30th Anniversary edition of Zeitschrift! It's hard to believe that our Volksie club is 30 years old already; where on earth has the time gone??

I was one of the founding members of Club VW, as we called it then, way back in 1985 when the VW scene was quite different from how it is today. The old VW clubs around then were actually 'all-makes', and were running dirt motorkhanas, rallies and bush bashes with only a few cut-down VW 'specials' or VW rally cars taking part. There were a lot more VWs on the road then and they weren't considered to be precious classics like they are now. Even so, there were only a few VW 'hot-up' shops, and no one was selling restoration VW parts anywhere. VW-only events, especially show'n'shines, cruises or swapmeets, were non-existent. In fact most club members drove Mazdas, Datsuns, Toyotas or Minis at events, and to work every day.

We formed Club VW to fix these problems, as we were a group of purely Volkswagen enthusiasts (as distinct from motorsport enthusiasts), who loved their VWs for what they were, not for how fast they could be made to bash around a dirt track. Our first gathering was at Parramatta Park on 10 February 1985, where nineteen VWs gathered together for an organised chat and a picnic. That first time we ended up driving to John Watt's place at Windsor, to watch the Love Bug on VHS. We all agreed to proceed with our new club, so after a first committee meeting (at my house!) we organised our first proper run, this time from Parramatta Park to St Albans.

Hence our 30th Anniversary Cruise on 8 March, also to St Albans! It would have been nice to start from Parramatta Park too, but it has been redeveloped over the years and the carpark in front of Old Government House has been removed. Hungry Jacks at North Parramatta is close enough – and you can brekkie and coffee there.

For the first couple of years our monthly meetings were held at Granville Town Hall, where Steve's wife Eileen and my then 15-year old sister Em made the tea and coffee. After that we moved to Concord RSL, then Auburn RSL, Auburn Soccer Club and finally the Greyhound Club, where we have been since 1999.



The club grew steadily until 1988, when we ran the first Boris' Picnic Day (at East Hills), then the first VW Nationals. This was the first large, professional VW show to be held in Sydney and began a tradition that is now in its twenty-eighth year, bigger and better than ever! The Nationals really woke up the VW scene in Sydney, and today we all reap the benefits of all the hard work put in by Dave Birchall, Steve Carter, Bob Hickman and the older timers Steve Muller, Rod Young, Caro and Ivy and all our members too numerous to mention.

Sometimes members want to know why we have modern VWs in the magazine and at our runs; aren't air-cooled VWs the only 'proper' VWs? Conversely, young guys with hot Golfs and Polos want to know why we also love the smelly ancient VWs. Well, the answer is that we have always been a club for both. We embrace all VWs, whether they be old or brand new, and we try to cater for both kinds. In fact, I've always said that happiness is having both old AND new VWs in your garage. Unlike the '80s and '90s, today there's a huge range of late-model VWs available on the new and used-car market, from little Polos to Golfs and Jettas to the luxury Passat; the retro Beetle or the topless Eos; fast and smooth T5 TDI Multivans for the family, and the Tiguan and Touareg SUVs. The Amarok ute. There's certainly no excuse for having a classic Bug, Ghia, Fastback or Kombi in your garage while you drive a Toyota, Ford or Mazda to work!

I believe today we have the ideal environment for VW enthusiasts. Club VeeDub is large and financially secure enough to put out the biggest and best VW club magazine in Australia; host a brilliant and much awarded website with more content than any other VW club website in the world; provide library books, magazines, tools, videos and DVDs for free use by our members, and organise any VW event you care to name. Yet, we have tried to make the whole thing fun at the same time. Our meetings are always entertaining—no moving and seconding the motion stuff—and we have a great bunch of people that makes getting together a joy. My daughter Lily has grown up with the Club, and says it feels like family. There really is something for everyone.

Let's see how the names have changed – and also stayed the same – over the years. What happened to some of these people we don't see any more? Do they still drive a VW?

President 1985 Chris Edwards
 President 1995 Ivy Martin
 President 2005 David Birchall
 President 2015 Steve Carter

Vice President 1985 Rod Young
Vice President 1995 David Birchall
Vice President 2005 Leigh Harris
Vice President 2015 Craig Adams

Secretary 1985 Phil Matthews
Secretary 1995 Rod Young
Secretary 2005 Bob Hickman
Secretary 2015 Norm Elias

Treasurer 1985 Luis Guevara
Treasurer 1995 Caro Martin
Treasurer 2005 Martin Fox
Treasurer 2015 Martin Fox

Editor 1985 Phil Matthews
Editor 1995 Paul Tagg & Nikki Davis
Editor 2005 Steve Carter
Editor 2015 Phil Matthews

Merchandising 1985 Stephen Muller
Merchandising 1995 Caro Martin
Merchandising 2005 Raymond Rosch
Merchandising 2015 Raymond Rosch

Raffle Officer 1985 Steve Carter
Raffle Officer 1995 Christine Eaton
Raffle Officer 2005 Christine Eaton
Raffle Officer 2015 Christine Eaton

General Committee 1985 – Andrew Dodd, Julie Pride, Bob Parry, Alice Brandtes, Steve Sagud, John Hall, Tom Subi, David Cameron Rogers

General Committee 1995 – Paul Tagg, Nikki Davis, Frank Watkins, Boris Orazem, Ron Croft, Sarah Crane, Jim Hudson, Darryl Donald, Brian Walker, Geoff Hadden, Simon Matthews

General Committee 2005 – Leigh Harris, Keith Haeusler, Sebastian Semos, Andrew Rankin, John Vellis, Peter McQueen, Ray and Shirley Pleydon, Michael Said, Danny McFaddyn, Belinda Godfrey

Older Zeitschrifts.

The first issue of Zeitschrift was February 1985. It was made of only 5 sheets of A4 paper, stapled together. The cover was photocopied (at my work!) while the rest was printed with a Gestetner mimeograph machine. This involved a two-layer wax stencil, which was fed into my Dad's Olivetti portable typewriter. The page was then typed (using no ribbon, just the hammers), with any mistakes having to be patched with a hard-drying pink fluid like toenail polish. Photos could not be done. Drawings and hand-lettering could be done by scratching lines in the stencil with a sharp point, like one side of a pair of compasses.

The finished stencil was then fed onto the Gestetner drum. Some machines were electric,



but our machine was a hand-cranked example that we borrowed from Darryl Donald at Rogate Spares. As the crank turned the drum, thick black paste-like ink was forced through the porous drum surface, through the stencil (cut by the typewriter) and onto the paper as it was drawn past it. All going well the wet printed page was then ejected into the tray, but more commonly it would jam or stick to the drum. It was a filthy, gooey machine to have to clear out. Old clothes or overalls were a necessity!

Address labels were hand-written for the first few issues, but we bought our first computer in June 1985. This was not a PC, but an Olivetti TES501 Text Editor, about the

size and shape of an office desk. It could store 128K on two 5" floppy disks, and had an LCD screen that showed one line at a time. System memory was a mighty 8K (that's 8192 bytes!) It was over \$10,000 when new in 1981, but we got it second-hand for \$200. I used it until the July 1986 issue, when it had

a fatal hardware failure. Rod Young had bought an Apple IIe computer by then, and was able to take over. The Olivetti went to Simsmetal shortly after that.

By the time of the fifth anniversary issue in February 1990, Rod Young had been controlling the magazine for three years, but with the idea of farming out the editorship of individual issues to different people for different themes, whether it be a special issue on Campmobiles, or Type 3s, or

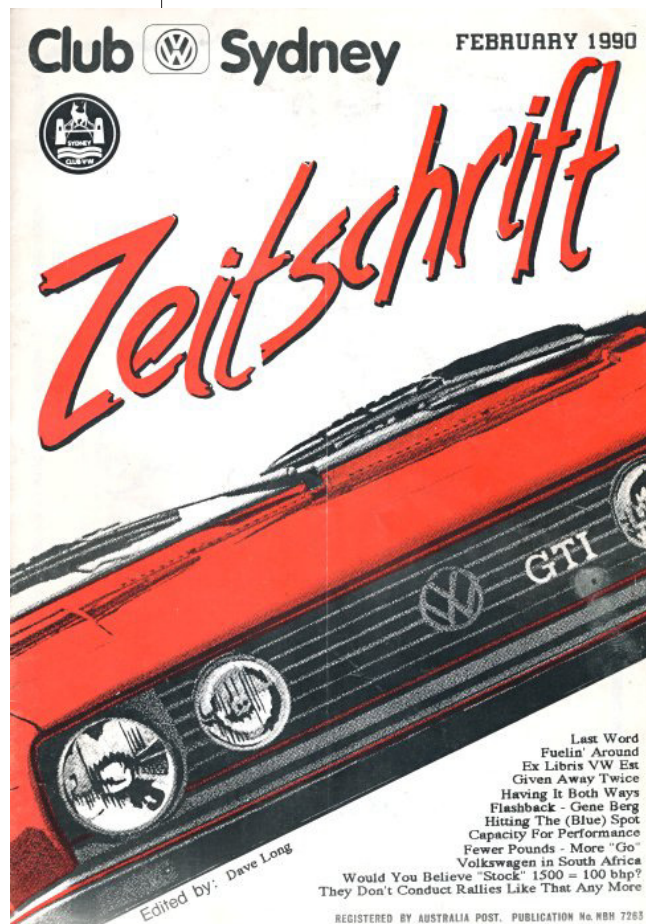

Audis, or whatever. Dave Long edited the February 1990 'anniversary' issue.

The magazine was much improved over my early issues. Printing and formatting was done by Rod on his Apple IIe, which allowed different fonts, right justification, two columns, and page headers and footers. Column sheets were printed, cut out and pasted onto a 115% layout sheet, with any pictures and photos and decoration added at the same time. Photos had to be converted to 'bromides', which changed them into the newspaper-style dot layout for printing, but that was expensive. I found you could get away with photocopying them through a translucent 'white dot' plastic sheet.

Advertisements were also possible, using proper artwork.

The finished layout sheets were then taken to our printers, Printmail at Artarmon, where they were shrunk to 85% and printed onto large A3 sheets, then collated, folded and stapled. The cover was thicker, mono-colour and glossy and had to be one-side printed a year in advance, which 'locked in' any advertising. I remember this caused dramas with one advertiser who had prices showing in his ad. Of course he insisted on changing them a few months later. We ended up throwing out half the stock and reprinting, at great cost – more than the ad was worth, as I remember.

Dave Long took over editorship in 1990 but left in acrimonious circumstances in 1991 and I took over as caretaker editor. He had written a stinging criticism of 'VW Power' magazine for getting their facts blatantly wrong about the Karmann Ghia. Their publisher got all upset, complained and threatened to withdraw their support of the VW Nationals. Dave was therefore asked to retract or apologise, which he (rightly in my opinion) refused to do, but rather than stand firm he then quit, and we've never seen him since. As it turned out, VW Power wasn't a financial sponsor, just a 'supporter' who still charged us for the copies of their magazine. They went out of business not long after anyway. But it earned respect for our magazine and its editorial strength, which was continued under the new editor Phil Lord, a club member from Canberra who was a journalist. He did a great job, but

the travel was a hassle for him.

In 1994 Paul Tagg and Nikki Davis took over from Phil Lord and shared the editorship job. For the 10th birthday issue in February 1995, I volunteered to do a special anniversary issue. For the first time we used Microsoft Publisher, and I designed a two-column template with Club Veedub page footers. I used it for a few more guest issues, but Paul and Nikki's single column layout survived another couple of years. Steve Carter changed the format again when he took over the editorship in August 1996, when he also began using MS Publisher. It made things so much easier, and also much cheaper. Printmail's costs were unsustainable, so Steve greatly reduced the layout and used a photocopier in his front room at home to print the magazine. We used to collate, staple and envelope the mag at the committee meetings.

By the time the Feb 2000 (15th anniversary) issue rolled around, Steve Carter had really fallen in love with MS Publisher and had much improved the cover design and the general layout. The internet was ramping up and Steve was

able to find lots of good stuff for the magazine from his net surfing. As you can see, we also had our own website (with our own domain name) by this time.

By the early 2000s Steve's wife Eileen was getting tired of having a stinky photocopier in her front room. One of Steve's mates happened to work for Snap Printing at

Penshurst, and was able to quote a price only slightly more than the cost of the copier's paper, toner cartridges and regular repair bills – not to mention the savings on Steve's timer in copying and collating. Snap was able to print, collate, staple and fold the entire run (around 300 copies), with Steve only having to burn a CD of the MS Publisher's 'export' file and drop it in to them. I generally guest-edited one or two issues a year.

Steve was still editor for the 20th birthday issue in 2005, but again I volunteered to do an Anniversary issue. Snap's print quality was great, and they had moved from Penshurst

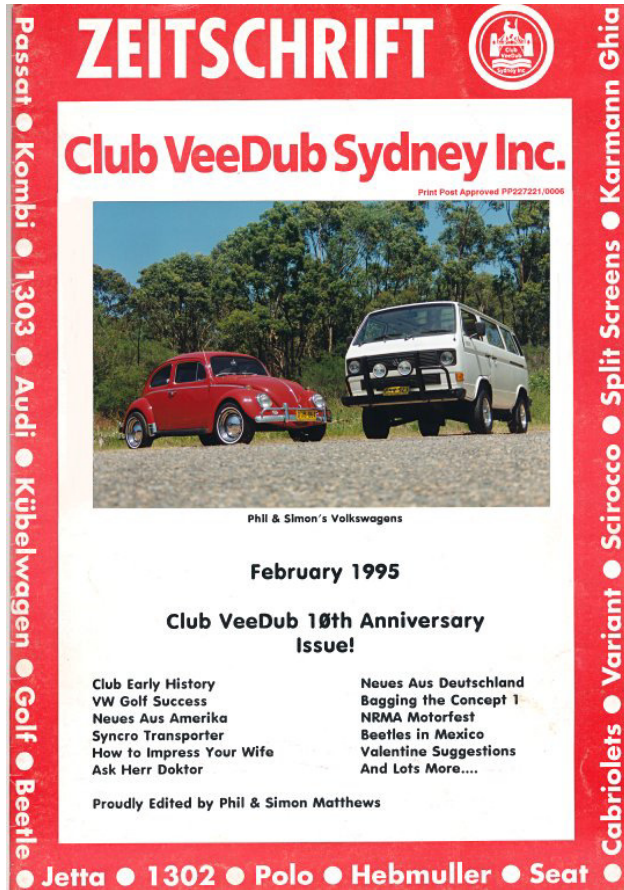

to bigger new premises at Kingsgrove. Technology now allowed the mag file to be dropped in to them on a USB stick, rather than burning a CD every month.

Apart from being the 20th birthday of the club, the February 2005 issue was very special for me as it marked the passing of my Dad Peter from cancer (aged 67) the month before. Dad instilled my love of VWs from the very earliest days. He and his mate Tony Foster both bought used 1954 VWs in the late '50s when he was a trainee teacher in Parkes. Dad used to race back to Sydney every weekend to court Mum, and used to boast he could drive the 61 miles (99 km) from Parkes to Orange in 59 minutes! He wrote the '54 off one evening sliding into a ditch somewhere west of Orange. He bought a brand-new Manly Tan VW 1200 from the Parkes dealer, R.R. Nock Pty Ltd, in March 1959. He was to keep BTF-933 for another 19 years.

He and Mum married in 1960 when he transferred back to Sydney, and I came along in 1964, followed by Simon in '66, Andrew in '67 and Emma in '70. Of course our first trip home from the hospital was in BTF-933. We all grew up in the VW, sitting in the well behind the back seat, tearing the upholstery and chewing on the rubber retaining strap before we were old enough to sit on the back seat. Dad went through a few engines in the '59 over the years, and many times I remember him working late in the garage on Sunday evening trying to get the engine back together and in so he could get to work next morning.

I was just old enough to learn to drive in the '59 before Dad sold it to his mate Johnny in 1978. Johnny later sold it to a young guy up the road who wrote it off. I just had to put a photo of Dad's '59 on the cover – complete with its '70s orange respray and the later model tail lights (he'd removed the trafficators and bogged up the slots years before). Thanks Dad, for teaching me to love VWs.

Steve stepped down as editor in 2006 to concentrate on being webmaster, and so I took over. I'm still here! I changed from MS Publisher to Adobe Pagemaker, as it's a bit more powerful and could create full-colour PDFs directly from the menu without having to find an extra utility such as PDF995. We could now permanently archive each monthly issue on the webpage, where they could be downloaded at any time (older issues by anyone; new issues by members only). I also started to re-edit and post the best of the 1985-2006 articles on the website. I still haven't finished that project.

ZEITSCHRIFT
February 2005

20th ANNIVERSARY ISSUE!

Club Veedub Turns 20!
News From Germany
August Horch Museum
The Toy Department
Roadside Blues
...Plus all the usual stuff in your bumper souvenir issue!

Old Zeitschriften
Herbie Rides Again
V6 Caravelle
Motoring Firsts
Dead Race Tracks

A CLUB VEEDUB SYDNEY PUBLICATION
Proudly a member of the Council of Motor Clubs

By the 25th birthday in 2010 the magazine was 40 pages, and the layout design was more or less standardised, using VW-style Futura font and including a VW crossword (since discontinued from lack of interest). There was now a different full-page classic Australian VW ad in every issue, as well as the latest VW news and information, the Toy Department, club run reports and photos and the most interesting VW tech and history stuff we can find, with the very minimum of advertising. It's the biggest – and I reckon the best – VW club magazine in Australia and one of the very

best in the entire world. It's certainly lasted longer than almost all of the professional VW magazines!

In 2012 we made the big decision to electronically distribute the magazine as a full-colour PDF to our members, rather than printing and posting a black and white magazine. Some older members without computers still got a printed

copy, but the print run was cut by three quarters, greatly saving on time, money and work. And yes, the magazine looks much much better in colour.

Today's issue is a further evolution. Last year Snap Printing changed owners and their quality dropped significantly, so we moved to a new printer, Minuteman Press at Peakhurst. Those still getting a printed copy will have seen how much better it looks now. They are even closer to Steve, Dave and me, and of course no CDs or USBs required – the finished PDF is just uploaded to the printer's website every month.

Thank you to those members who regularly send stuff to editor@clubvw.org.au for the magazine – Tony Bezzina, Bruce in Canberra, Joe Buttigieg, Peter James and many others too. Please keep the cool VW stuff coming!

Zeitschrift

Volkswagen wins Dakar Rally 2010.

February 2010

IN THIS ISSUE:
VW Summer Run
NRMA Motorfest
Canberra Chapter runs
Beer Can Buggy

Wally's Corner
Marulan Truck Day
The Toy Department
Plus lots more...

Club Veedub Sydney.
www.clubvw.org.au

A member of the NSW Council of Motor Clubs. Now affiliated with C.A.M.S.



Duke's Day at Freshwater Beach.

On Saturday 10 January the Freshwater Beach Surf Club ran their annual 'Duke's Day' surf and Kombi show. This celebrates the first demonstration of standing up surfboard riding in Australia, by the legendary Hawaiian swimmer Duke Kahanmoku. He first rode his home-made wooden board at Freshwater beach in 1915, so this year was the 'Centenary' celebration.

A VW Kombi display is a welcome part of the day, since many people associate Kombis with surfers and the sunny beach culture – and why not! Freshwater Surf Club put the invite out to the VW forums and the VW clubs, and their flyer was in the December issue (page 8).

I went last year and had a great time. I was the only Club VW Kombi, as all the others were from the Kombi Forum. This year promised to be bigger and better.

It was still the school holidays, so there was no need to rush. Lily really wanted to come this year, so we washed and polished the Kombi, grabbed our overnight bags and our cossies and headed up to the northern beaches on Friday afternoon.



We headed a little further north of Freshwater, to Collaroy where I knew the beach had better waves and better facilities. We parked the Kombi by the beach and enjoyed a swim in the surf in the late afternoon. Collaroy was unpatrolled and there were only a few other swimmers enjoying the dumpy waves. We only went out a little way but enjoyed the crashing foam and bodysurfing in when could get to the break point. There was strong rip a little to the south but we only felt it when we had waded almost out.

After a cold beach shower and a change, I took Lily for a walk around past the rock baths to little Fisherman's Beach, just north of Long Reef. As it was getting dark we threw rocks into the waves and then wandered back to the kids' play area. We

wandered over to the lovely old Collaroy Cinema, but there was nothing on that Lily wanted to see. Instead we ordered garlic bread and a cheesy margherita pizza from the restaurant next door and took them back to the Kombi to eat.

Eventually we camped down in the Kombi, with the ocean sounds and breeze drifting in through the roof as we



went off to sleep. I'd set the alarm for 6:30am, and in no time it was morning. The locals were already arriving for early morning swims as I packed up, Lily reluctantly getting up just before we left. I then drove back down through Dee Why and Brookvale to Freshwater.

The carpark behind the surf club was already busy, but the council man directed us straight onto the entrance to the grassy field where half a dozen Kombis were already parked. We parked in line and set up our club display, by which time another half dozen had arrived.

Wayne and his folks soon arrived in his blue bus, and later John in his maroon Kombi. It was a good turnout, with

eventually around 20 Kombis in a line. Most of them were '68-'79 T2 models, but also a good handful of earlier splitties. There were no later models in the show display, but I did spot a couple of T3 Kombis out in the public area, and a few of the shop traders were driving new T5s.

There were plenty of things to see and do, with trader stands selling all manner of swimming and surfing kit. Surfboard shops had their latest boards on display, as well as a few retro-looking malibus and long boards. Some were shaping their own from blocks of foam and soft wood. There were great looking wooden surf boats to look at too, and some of the food stands were selling Hawaiian fruit and sugar cane juice.

Freshwater beach itself is not that big, and the whole area was crowded. Most of the beach was taken up with official festivities, including kayak and paddle board races, running and swimming and official speeches. There



club brochures. The Kombi owners enjoyed chatting to one another, coming as they did from all sorts of backgrounds.

By 3pm things were winding down and Lily was tired, so we packed up and headed home. Our Kombi needed another wash afterwards, as it had beach sand on the floor and dried salt spray on the paintwork! I love the beach but sometimes it's nice to be a westie too.

A fun day and I'm sure we'll be back next year.



was a large sausage sizzle put on the surf club. At midday there was a reenactment of the Duke's first surfboard ride, using a heavy new replica of his 1915 plank board, with no fin! You could see the Duke's original board in a glass case in the surf club.

Unfortunately the weather chose to be cloudy and a little cool, with hardly any swell. There was a burst of applause when the Hawaiian guy rode the Duke board on the wave for the first time.

A small portion of the north end was open for public swimming, but the marshals were very strict about keeping in the zone between the flags on such a busy day. The water was full of sea weed and there were long quiet periods of flat seas before a few small dumpers rolled in. We didn't stay in very long.

After an ice cream and sausage roll Lily only wanted to relax near the Kombi. There were lots of passers-by, and I gave away about 20





waiting. Jeff turned up in his Superbug shortly after, and by 9am there were already half a dozen VWs, old and new. There was plenty of time for a coffee.

Steve had printed off some Google Map sheets of the route and handed them out, so no one ought to get lost. We wandered about the cars before departure, introducing ourselves to the drivers and mentioning that it was cruise – slow down and stick together.

At 10:00am we started up and headed off, more or less together, but soon the fast modern Golfs and their young drivers shot off ahead. Some of the air-coolers were left behind, including one Beetle that actually broke down near the start. I was almost the last to leave in my Bora and drove to Appin pretty much on my own. Matt had parked his Mk2 Scirocco on the left as you enter

Appin, at the Lions sports park where the big group of cars were parked together.

VW Watercooled Summer Cruise 2015.

Sunday the 1st of February saw the ninth running of the Watercooled VW Summer Cruise. It's so named because it's always been organised by Aaron from the vwwatercooled forum, not because it's only open to water-cooled VWs – it isn't. In fact, there were more old air-coolers this year than ever before. Aaron of course has also been our webmaster for a number of years.

This year would prove to be a challenge, as Aaron had to move to Melbourne for his work and would not be available to organise and run the day. Our club has previously supported the event in a major way, so this year we would have to step up and take it over completely.

Steve Carter volunteered to be in charge of the cruise from the start at Uncle Leo's, while Matt White would organise the gathering at Appin, the half-way spot along the way. As for the BBQ at the end at Stanwell Park, Norm Robertson volunteered to pick up the trailer, BBQ, tent and gear from Bob's and set it up, with help from Rudy, Brian and me. All good!

The watercoolers like a lazy sleep-in start, and people didn't have to meet at Uncle Leo's until 9:30am. In fact normally it's a 10am start, but we wanted to allow more time for the half-way photo stop and gathering at Appin. I turned up at Uncle Leo's at 8:45am, where one Golf was already



I only stayed a few moments, then headed off before everyone else to get to the end to help set up. Steve and Matt stayed behind to marshal and lead the VWs later. I pushed fairly quickly along Appin Rd to the top of Bulli Pass, descended quickly then followed the weekend traffic from Thirroul to Coalcliff and the Sea Bridge, and the finish at Stanwell Park. It's a lovely large grassy park beside the beach kiosk and car park, and only a short walk to the ocean beach.

Norm and Rudy already had the tent set up, with Brian in his wheelchair supervising. We only had to put up the fold-





Eventually the food and drink was gone, people were heading off and we decided to pack up. There were plenty of bodies to fold up the tables, BBQ and tent, which we carried back to the club trailer behind Norm's SUV. I think everyone had a fantastic time, although Steve later mentioned some complaint from a member of the public (see his Pres report).

For next year, I think we only need to try harder to stick together in the cruise – maybe a loud hailer and the club walkie talkies could be used? And the club trailer is in desperate need of a sandblast, respray and some signwriting!

A fantastic day, and thank you to everyone from the club who helped make it a success.



up tables, cut the buns and sausages and fire up the BBQ. I estimated the convoy was less than 20 minutes behind me and would arrive in no time. Rudy soon had the BBQ steaming away, and in no time the first trayful of snags and onions were ready. Norm and I had both bags of crunchy buns cut and buttered, and had barely had time for our first drink when the first VWs started arriving.

The VWs were mostly able to park together in the shade of the trees in several rows, and the younger guys stayed there and chatted for a while before making their way over to the BBQ tent. The buns, snags and onions and sauce/mustard were very popular. It was only a gold-coin donation for a yummy roll and a soft drink.

Rudy and Norm were able to cater for everyone with ease, including those coming back for seconds. Matt was even able to bring a few beers, which certainly tasted great – thanks Matt. With the food and drink taken care of, it was enjoyable afternoon enjoying the sunshine and sea breeze and talking VWs, both with familiar faces from our club and the new guys from the forums.

I think there were around 30-40 VWs altogether, although it was impossible to say for sure as a few left early and there were some latecomers, including Rod Penrose who drove up from Unanderra. It was strange not to have Aaron to chat to and laugh with, and I'm sure the other guys missed him and his family too.



A brief history of ignitions.

If your VW engine gets its power from burning gasoline then you gotta figger out some way to light the fire. Always been something of a problem, lighting the fire. Back during the Civil War they used what they called a 'glow tube' to light the fire. Closed brass or silver tube, closed end inside the combustion chamber, open out outside being heated by a kerosene or acetylene lamp. Actually worked, too. Engine put out nearly half a horsepower at about 100 rpm and only weighed about 320 kg.

State of the art, 1865.

Of course, soon as they had an engine, some kid wanted to make himself a motorsickle. Or mebbe a hot-rod.

Didn't work too good. Soon as the thing started to move it would usually blow out the kerosene lamp, glow tube would cool off, engine would crap out. Ignition failure. Civil War motorcycle gang, Nazi helmets, Originals stiff as a board, lined up there on the side of the road... Hell of a problem.

Some guys used spark ignition. Low voltage, make & break stuff. But that meant a buncha batteries and they weren't all that good back before we had the Energizer Bunny. Or they could generate their own lektricity. Mike Whats-his-name... Faraday... had figgered out how to generate lektricity about thirty years before. All you had to do was twirly a coil of wire between the poles of a magnet and lektricity would magically appear in the coil. Unfortunately Civil War magnets weren't any better than Civil War batteries. Just soft iron bars. Oh, you could magnetize the things but not very much nor for very long. If you wanted to produce the same amount of current you'd get from your bank of batteries you needed some humungous magnets, size of a wagon wheel. Magnets that big, your lektricity-maker ended up weighing about the same as the batteries, not only because you needed a lot of big soft iron magnets but because your coil was kinda fat. Big wire. And the insulation was just string or varnished thread wrapped around the wires, which pushed the wires pretty far apart so you needed a BIG coil to get any juice. And slip-rings, since you had to get the juice out of the coil once you made it.

Folks called it a 'magneto' because of the magnets, I guess. First ones weighed about fifty kilos. But it actually worked and you ended up with an engine that was handier



MAGNETO IGNITION SYSTEM

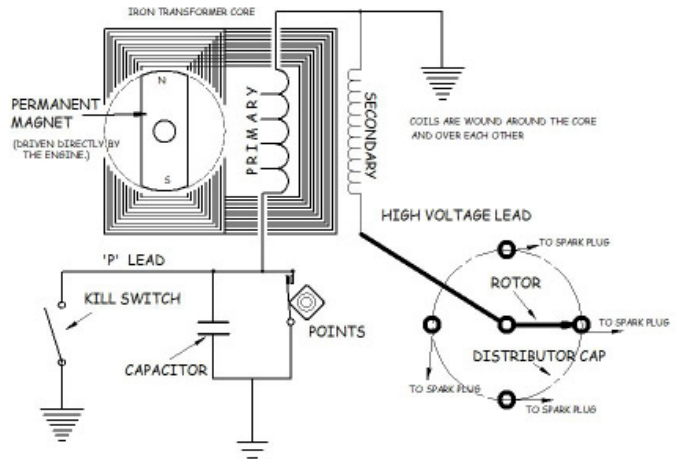

than steam because you didn't need a firebox and a boiler. Not a real handy engine, of course. Heavy as hell. Didn't put out a lot of power and only ran at one speed. But the fire was all inside and there wasn't any boiler to explode and you could run the thing yourself; didn't need a certified Engineer.

Wasn't a Hog of course but the thing did go. Bad as it was, it sold like hot-cakes since it cost less than a small steam-powered engine. And because it sold like hot-cakes a lot of people were building them. And improving them, too.

Twenty years goes by. Engines got smaller and more powerful. So did the magneto, thanks mostly to Elisha Gray, who developed a geared magneto that could produce nearly forty volts, thanks to stronger magnets, smaller wire, better insulation and those gears. That made the thing small enough to fit inside his telephones. Spin the crank, it could generate enough juice to trip the indicator down at Central, tell the operator you were on the line. Couldn't use light bulbs because Edison hadn't finished stealing the idea from Swan just yet but the solenoid-actuated ringdown indicator worked pretty good, assuming you weren't too far from Central and the iron wire running along the fence posts wasn't too rusty.

Better magneto made for a better engine but most real engines, like the ones in the trucks that could now be found all over Europe, still used glow tubes. Which sat the truck on fire now and then but glow tubes were more reliable than that silly Mag-Neat-Oh or that Make & Break method of generating the spark, rubbing the piston against the Sparking Rod inside the combustion chamber.

Stationary internal combustion engines had come even farther. Now that most towns had electric lighting they used a door bell arrangement to generate an alternating current that could be stepped-up by a transformer and fed to a spark plug, just as soon as they invented spark plugs. Didn't work for those trucks, though. The vibrating reed-relay that buzzed those coils up to as much as five thousand volts was a real power hog and ran down your dry cells quick like a bunny.

Which is why the Wright Brothers used Make & Break to light their fire. No spark plugs. Friction-drive magneto pressed into service as a dynamo, powered by putting a little wheel on the input shaft and letting it rub against the flywheel - gave them about ten volts. Sparking bar inside the combustion chamber. Tried and true ignition system, having been in use for nearly fifty years by the time the Wright brothers flew. They'd heard about a new-fangled high-voltage magneto developed by a German outfit. Put out enough

voltages to jump the gap on a spark plug, assuming you had spark plugs, which the Wright's didn't. Not at first.

Robert Bosch got into the magneto game in 1887 and made a pretty good magneto, although not very many of them. By 1896 he'd only sold a thousand of the things but he kept ploughing the money back into the business, improving his product. Because everyone understood that if you wanted to make a hot-rod or a motorcycle you couldn't afford the half-ton weight of the typical gasoline engine. Trucks, okay. But not motorcycles or flying machines or a Z-car. For that you needed a light engine. But it had to be a powerful light engine and all else being equal, that meant it would have to spin at a fantastic rate of speed, probably more than A THOUSAND REVOLUTIONS PER MINUTE, which was a lot faster than any engine was running at that time. Try running a Make & Break ignition at a thousand rpm, it'd break off the Sparking Rod or the insulated seal around the Sparking Rod gland-nut would leak even more than it already did and steal all your power. Carl Benz, a friend of Bob's and another early car nut, referred to the ignition puzzle as "...the problem of all problems." He said that in 1880 and odds are, he was still saying it in 1896. Nope. Couldn't do it.

BOSCH
MAGNETO
for **FORDS**

**MORE PEP
AND POWER
FOR YOUR FORD**
Rip Roaring Bosch

Sparks add pep and power to any Ford. The Bosch Special Ford Attachment will mean more miles to the gallon and hour and cut tire and repair bills. Bosch High Tension Magneto Ignition on your Ford will pay for itself in six months and give you a smoother, cooler engine. The nearest dealer can install the Bosch Ford Attachment easily and quickly without tearing down the engine. Get in touch with him today.

**AMERICAN BOSCH
MAGNETO CORPORATION**
Main Office and Works—Springfield,
Mass. Branches—New York, Chicago,
Detroit, San Francisco. *More than
200 Service Stations in Over 200 Cities.*

AMERICA'S SUPREME IGNITION SYSTEM
MOTOR TRUCKS - TRACTORS - AIRPLANES - MOTOR CARS - MOTOR BOATS - MOTORCYCLES - GAS ENGINES - ETC.

Actually, you could do it... if you used a Sparking Plug with a fixed gap instead of Make & Break with its moveable Spark Rod with its variable gap. In fact, they'd already done it with stationary engines. But to jump the gap on a Sparking Plug you needed thousands of volts, not just tens of volts. And while you could make that kind of voltage by plugging your ignition system into the wall, or powering a vibrator with a bank of batteries, nobody knew how to do that with a magneto.

Except for a guy named Gottlob Honold, who worked

for Bob Bosch. And even Gottlob wasn't sure he could do it, he just had this idea about how, maybe, it could be done, based on a couple of principles about inductance that Mike Faraday laid down fifty years before and some of the tricks Elisha Gray had come up with. Gottlob was lucky enough to be working for Bob, winding coils for those thousand pretty-good magnetos. Bosch told him, Sure, take your best shot at it. Which Gottlob did, solving one problem after another over a span of five years or so until December of 1901 rolled around and he showed his boss a working model of a reliable, dependable magneto that put out enough juice to be used with a spark plug. "You really have hit the bulls-eye!" said Bosch. (But in German, of course.) By 1906 Bosch magnetos was bringing in over a million dollars a year, thanks to Gottlob Honold, who was given a raise and allowed to take Saturdays off.

What Gottlob had done was to put a transformer inside the magneto and to apply a couple of known but heretofore undeveloped electrical theories to make the transformer kick out a hot, blue-white spark exactly when needed, using an electrical switch driven by the magneto. Once the spark was generated it was connected to the proper spark plug via a rotary switch that was also driven by the magneto. The first switch, which controls the flow of juice to the primary side of the transformer, is what we today call the 'points' while the second switch, the one that directs the output of the secondary winding to the spark plug, is called the rotor and distributor cap.

Starting to sound familiar? Well, it should. Because the principle of spark ignition has remained pretty much the same right up to this day, despite something better having come along in the 1960s.

As soon as the Bosch high-tension magneto hit the market everyone started copying it. Or trying to improve on it. Like a young guy named Charles Franklin Kettering who worked for the National Cash Register Company in Dayton, Ohio. Which just happens to be where the Wrights hailed from. In a sense, Dayton was the Silicon Valley of its day.

Magnetos were nice. Nice and expensive. Each was virtually hand-made. Their superb quality ensured their reliability but it also guaranteed the need for a high level of skill to maintain and repair them. They were a complete generating set and ignition system compressed in a tidy little package. And if any single part of that tidy little package went bad, the thing wouldn't work and finding someone who knew how to fix it was roughly the same as for finding fur on a turtle.

But magnetos weren't perfect. Since the amount of juice provided by the permanent magnet dynamo was proportional to the rotating speed of the coil, they were a bitch to hand-start. Once you got the buggy running things were okay. The faster it ran, the better the spark, up to the point where the electrical insulation began to break down. Hand-cranked on a cold morning? Forget it. Ford's buzz-box 'ignitors' were the hands-down winner when it came to crank-starts because when you got right down to it, your horseless carriage was pretty much of a joke if you couldn't start the thing. And for a lot of folks, crank-starting a car was about like programming their VCR.

Kettering thought about the problem for a while then decided to take the magneto apart. Instead of that nifty little permanent magnet dynamo to provide the juice he decided to

KETTERING IGNITION SYSTEM

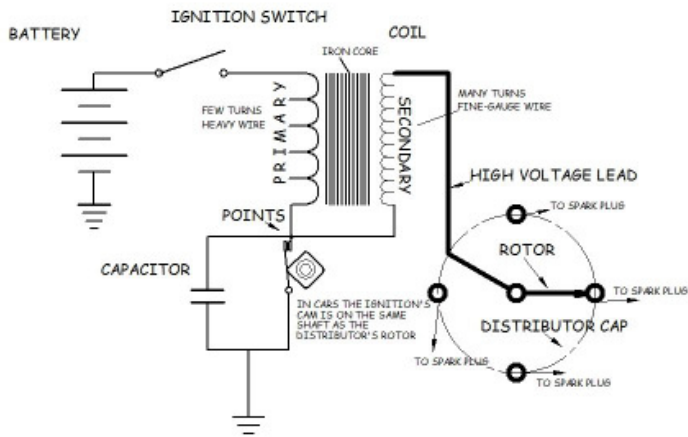

run the thing off a big lead-acid car battery. To keep the battery charged you'd have to fit the engine with some kind of electrical generator but now that Edison had copied the light bulb folks were even using them on cars, not only to replace the blindingly expensive acetylene-powered driving lights but even for that new fad of having a light come on when you stepped on the brake. (Cute. But it'll never catch on.) And besides, Chuck had a crazy idea about replacing the hand-crank with an electrically powered starter-motor, for which you'd need big battery and some means of recharging it.

After tearing the magneto apart and spreading it around the table Chuck saw how you could retain the transformer principle that gave you such a nice hot spark while eliminating most of the complexity that made magnetos so expensive. Instead of building the transformer inside the magneto Chuck Kettering wound a new transformer, one you could bolt anywhere you wanted it. He put the points in a device driven off the engine's cam. The points went into the bottom part of the thing. The top part was reserved for the task of distributing high voltage from the coil to the individual spark plugs, which everyone started calling the 'distributor' about ten seconds after Chuck invented the damn thing.

Now you had all the pieces of an effective spark-ignition system spread out where you could get at them. The components were larger and designed for mass production; no brains required. If a part of the system went bad, any damn fool, meaning you, could simply replace that particular part and drive on. What you ended up with was a cheap, easily manufactured ignition system that was inexpensive, reasonably reliable, didn't cost very much and took virtually no skill at all to maintain. And it was cheap. Best of all, it

KETTERING - WASTE-SPARK SYSTEM

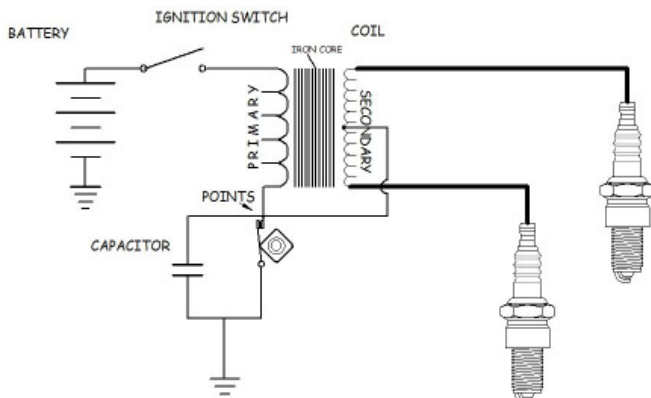

actually worked. (Did I mention it was cheap? Cuz it was, compared to a magneto.)

Genius or not, Charles Kettering hadn't improved on the magneto in the electrical sense. Indeed, at high speed the Kettering ignition system doesn't work nearly so well as a magneto. But boy did it make an engine easy to start! And it was cheap, too.

Auto makers loved it. At least, most of them. Ford stuck to his own patents. A fellow named Sloan, maker of a car he called the 'Cadillac,' took one look at Charles Kettering's ignition system and said, "I'll take a million of them, please." (Or words to that effect :-)

Which isn't to say magnetos vanished. Far from it. But over the years the Kettering-type ignition system got better and better while magnetos stayed pretty much the same.

First big improvement was getting rid of that distributor with its rotor and graphite button and all them sparks as the thing whirled around. Just a year after Boss Kettering patented his ignition system a feller in England started using it on a two-cylinder motorsickle. What he did was to wind the coil with a centre ground so that both ends of the secondary were hot. Snap the points, which you could now mount just about anywhere, and you got two sparks, one from each end of the winding. He wired the sparks to his two cylinders and roared off to win the Isle of Man.

Waaait a minute. Howz that gonna work, both cylinders firing at the SAME time. But the feller just smiled and roared off. From that day to this no one has been able to figure out how a Waste Spark ignition system works, largely because Auto Shop 101 doesn't do a very good job of teaching how real engines work. But I'll give you a hint: It doesn't really matter what the other cylinder is doing when the spark fires. So long as that jug is near TDC on the compression cycle, then the engine will run... because if that jug is near TDC it means its twin is near TDC on the exhaust cycle, because that's how Otto Cycle engines operate. The Good News is that you got to toss that damn distributor in the trash. You still had a set of points... somewhere. But they didn't cause nearly so much trouble as that wonky distributor cap and rotor and having the ignition leads running all over the place.

That was in 1920, by the way.

In 1960 I built my first electronic ignition system and I wasn't the first guy to do so (I hold a General Class ham radio ticket; hams are always fooling with stuff like that). Later on I built a capacitance-discharge ignition system. And a little while after that I built an ignition system that runs off a dilithium crystal, which worked great except those damn crystals became rare as hen's teeth after they canceled 'Star Trek.'

Nowadays they're working on a spark plug that contains its own coil which also happens to be a fuel injector. But that can't be right, according to Auto Shop 101 :-). It's also possible for someone building their car to put together an ignition system that is more durable and more reliable than the traditional magneto. Wanna know how? Just stay tuned.

Bob Hoover

Sit beside "Granny" Hayes and discover **VOLKSWAGEN** — a new world of comfort and performance



Charlotte ("Granny") Hayes, outstanding woman driver, says: "I discovered Volkswagen in the 1955 Redex — found there was only one car to beat it — another Volkswagen. Here's your chance to discover this brilliant performer."



An unmade road — feel how Volkswagen's torsion bar suspension, independent on all four wheels, cushions every bump. No other car in its class has torsion bar suspension.



On hot, dusty roads the air-cooling system automatically keeps the engine at correct temperature. No radiator to over-heat, no leaky connections or other water-cooling problems.



Up a steep hill — the rear mounted engine gives greater drive. Changing up, or down, is child's play, because 2nd, 3rd and 4th gears are synchronised.



Around this corner with a flick of the wheel. It's easy to manoeuvre Volkswagen in heavy traffic because steering responds to fingertip control. No shake, no shimmy.



Volkswagen is perfect for shopping expeditions. So easy to park — slips into a space little longer than the car. Lots of space for your parcels behind the back seat and under the bonnet.



Look! Volkswagen's streamlined, sloping bonnet gives you an unrestricted view of the road — almost up to the front of the car. It's safer, more time for braking.



There's a Volkswagen Service Station! Travelling interstate or abroad — wherever you go — you'll find an authorised Volkswagen Station at your service. Just look for that famous blue VW sign.

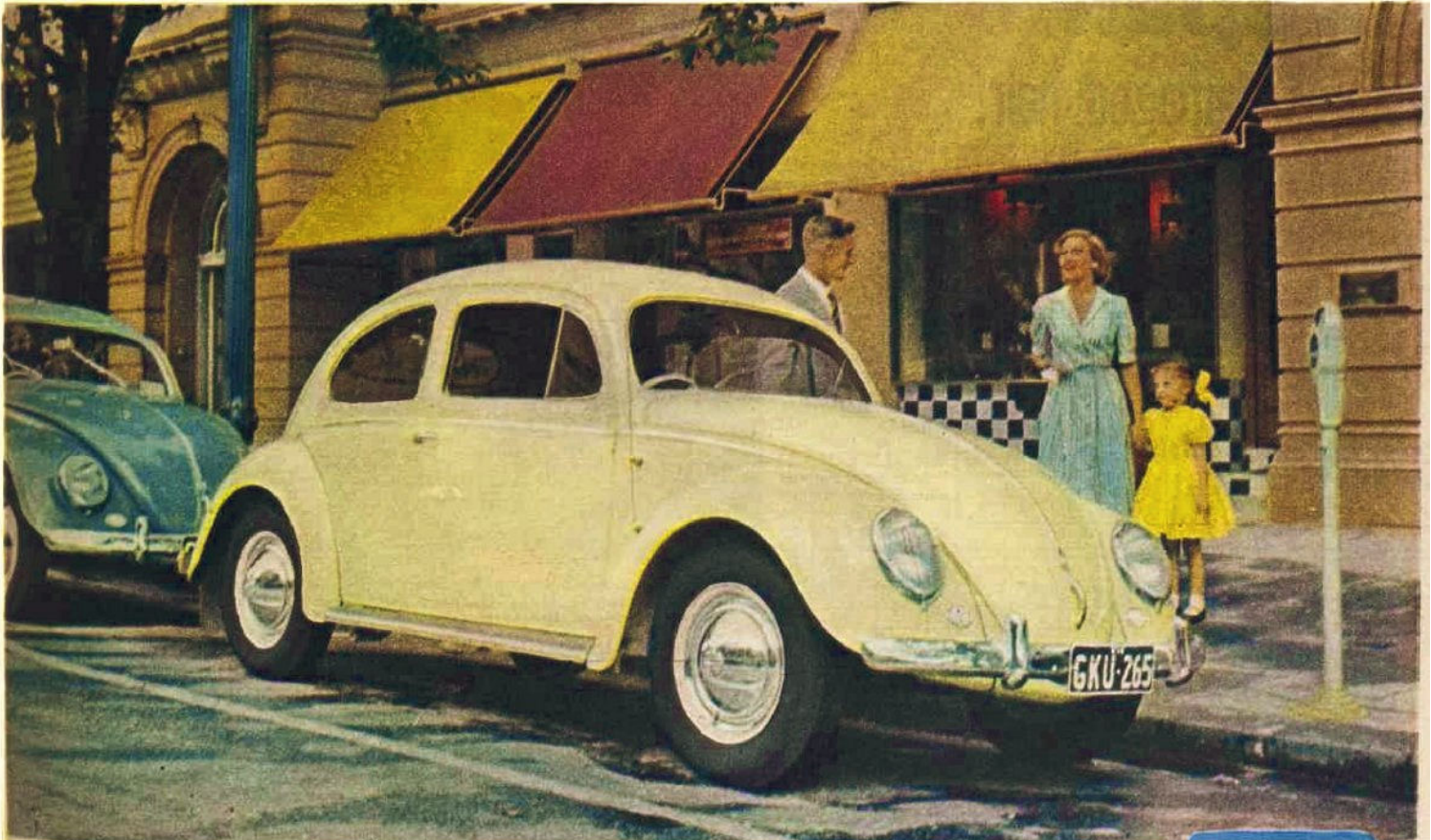

"GRANNY" HAYES has told you about Volkswagen performance. Next thing to do? Discover the **thrill of driving Volkswagen for yourself.**

Sit back — see the road skimming beneath you as you dart off the mark — swiftly, smoothly. Feel the surge of power from the 14.8 h.p. engine. Hear its slow revving purr — no strain, no wear — mile after mile.

Your reliable Volkswagen gives you economy, too. You can cruise 38 miles on only one gallon of petrol — 4½ pts. of oil each oil change.

Unique after-sales service. A special service booklet contains voucher coupons showing maintenance and lubrication operations to be carried out at regular mileages. Coupons quote exact prices — no estimating. Trained mechanics work with Volkswagen-designed tool kits — give you fast, efficient and inexpensive service. And, spare parts are always in full supply.

Over 11,000 Australians have discovered Volkswagen — throughout the world, over 40,000 Volkswagens have travelled more than 60,000 miles without major repairs. Arrange with your Volkswagen distributor for a trial drive. Discover for yourself this new world of comfort and performance — Volkswagen, Australia's best car value at £971, inc. sales tax.

VOLKSWAGEN (AUSTRALIA) PTY. LTD.

Distributors in all States — and a Commonwealth-wide network of service.



VW NATIONALS Sponsors 2014.

We wish to extend a sincere *thank you* to all of our sponsors below, who made the VW Nationals 2014 possible. Please support them, because they support us.

Volkswagen Group Australia	1800 060 936 (FREECALL)	Klassic Kombiz	0411 170 729
A.J.Cody VW Performance	(02) 4325 7911	MacKellar Service Centre	(02) 9939 2467
All Metal Bumpers	0438 765 098	Mick Motors	QLD (07) 3266 8133
Andrew Dodd Automotive	(02) 9683 2184	Millennium Bug	themillenniumbug.com.au
Antique Tyres	VIC (03) 9458 4433	Mobile Auto Models & Toys	0403 012 060
Artemi's T-Shirts	0415 163 313	Motexion Bulkheads	1300 563 333
Australian VW Performance	VIC (03) 9725 5366	Mountain Mechanics	0418 426 487
Beyond Limit Autos	(02) 8854 2080	NRMA Vintage Classic Insurance	1800 646 605
Black Needle Motor Trimming	(02) 4722 5333	North Rocky Mechanical	QLD (07) 4922 0555
BWA Auto	(02) 9838 7373	Nulon Australia	1800 679 970
C & S Automotive	(02) 9774 3340	Pacer Auto Products	(02) 9647 2056
Camden GTI	0423 051 737	Quik Strip Bankstown	0418 440 131
Canberra VW Centre	ACT (02) 6253 1481	Red Van Tyre Colouring	0408 254 574
Classic Vee Dub	(02) 9638 4200	Reliable Automotive Services	(02) 9438 3830
Cupid Wedding Cars	0419 494 465	Rod Penrose Racing	(02) 4272 9920
Custom T-Shirts & Trophies	0407 946 939	Shannons Classic Car Insurance	13 46 46
Custom VeeDub	QLD (07) 3356 4356	Stan Pobjoy Race Engineering	(02) 6654 3694
Defender Safety	(02) 9838 8986	Subarugears	0419 243 275
Eagle Wolf Spirit Dreaming	0488 555 497	Unicap Pty Ltd	(02) 4777 4006
East Coast Kombis	(02) 4324 1205	Vintage Vee Dub Supplies	(02) 9789 1777
Euro Revolution	0430 435 489	Volkswagen Autos	(02) 9688 2933
Exoticars Service Centre	(02) 9683 2110	Volkscare	VIC (03) 9729 9281
Expert Signs	0416 258 763	Volkshome Automotive	VIC (03) 9464 0366
Forty Horse T-Shirts	fortyhorse.com.au	VolksMüller	(02) 9679 2900
Gold Coast Vee Dub	QLD (07) 5537 6200	Volkswerke	VIC (03) 9435 1868
H & M Ferman	(02) 9533 2722	VW Classic Kirrawee	(02) 9521 5333
Harding Performance	QLD 1300 730 949	VW Magazine Australia	QLD (07) 3806 1240
Indian Automotive	(02) 4731 64441	VW Spectacular	0427 695 203
J.C. Fry's VW Spares	(02) 9438 4588	Wayne Penrose VW	(02) 4272 5644
Just Kampers Australia	(02) 9645 7660	Westside Mufflers	(02) 9773 7244
Kemp Tools	0402 888 822	Wolfsburg Automotive	VIC 1300 370 310
Klaack Motors	(02) 9724 5901	Wolfsburg Motors Sydney	(02) 9519 4524
		Wurth Australia	1300 657765



VOLKSWAGEN
GROUP AUSTRALIA